

<R42-186-0>

Service Manual

QUADRAPHONIC RECEIVER

QX-8000 / FW

<71102M31D>

PIONEER®



CONTENTS

1. SPECIFICATIONS	1
2. FRONT PANEL FACILITIES	3
3. CONNECTION DIAGRAM	5
4. CIRCUIT DESCRIPTION	
4.1 BLOCK DIAGRAM	7
4.2 FM AM UNIT	9
4.3 HEAD AMPLIFIER	10
4.4 HIGH LEVEL INPUTS AND CONTROL CIRCUITS	10
4.5 CONTROL AMPLIFIER	10
4.6 FILTER	10
4.7 POWER AMPLIFIER CIRCUIT	10
4.8 POWER SUPPLY CIRCUIT	10
4.9 Q UNIT	10
5. DISASSEMBLY	
5.1 WOODEN CASE	13
5.2 FRONT PANEL	13
5.3 BOTTOM PLATE	13
5.4 PARTS AND PCB LOCATION	14
6. ALIGNMENT PROCEDURE	
6.1 FM IF ALIGNMENT	15
6.2 AM IF ALIGNMENT	16
6.3 FM TRACKING ALIGNMENT	17
6.4 CHECKING OF MUTING FUNCTION	17
6.5 AM TRACKING ALIGNMENT	18
6.6 MPX DECODER ALIGNMENT	18
6.7 CHECKING THE SCA FILTER	19
6.8 CHECKING THE STEREO INDICATOR	19
7. DIAL CORD STRINGING	20
8. SCHEMATIC DIAGRAMS AND PCB PATTERNS	21
9. PARTS LIST	40
10. PACKING METHOD AND PARTS	58

1 • SPECIFICATIONS

SEMICONDUCTORS

FET	1
ICs	2
Transistors	65
Diodes	27

POWER AMPLIFIER SECTION

Music Power Output (IHF)	180 Watts (4 Ω) 130 Watts (8 Ω)
Continuous Power Output (2 channels driven)	32W + 32W/32W + 32W (4 Ω) 25W + 25W/25W + 25W (8 Ω)
Continuous Power Output (4 channels driven)	25W x 4 (4 Ω) 20W x 4 (8 Ω)
Power Output in the range of 20Hz to 20kHz (2 channels driven)	21W + 21W (8 Ω , Harmonic Distortion Less than 1%)
Harmonic Distortion	Less than 1% (Continuous power output) Less than 0.2% (20W + 20W/20W + 20W, 8 Ω)
Intermodulation Distortion	Less than 0.4% (20W + 20W/20W + 20W, 8 Ω)
Power Bandwidth (IHF)	15Hz to 80kHz (8 Ω Harmonic Distortion Less than 1%)
Frequency Response	5Hz to 100kHz, ±3dB
Input Sensitivity/Impedance (1kHz, Continuous power output)	400mV/70kΩ
Speakers	4 to 16Ω
Damping Factor	35 (8 Ω 1kHz)

PREAMPLIFIER SECTION

Output Voltage	400mV (Rated output), 2.5V (Max.)
Harmonic Distortion	Less than 0.7%
Frequency Response	10Hz to 40kHz, ±3dB
Input Sensitivity/Impedance (1kHz, for rated output)	PHONO 1 2mV/50kΩ PHONO 2 2mV/50kΩ AUX 1, 2 170mV/110kΩ TAPE MONITOR 1, 2 180mV/120kΩ
Recording Output	TAPE REC 1, 2 (Pin jack) 170mV
BASS Control	-12dB, +11dB/100Hz
TREBLE Control	-8.5dB, +10.5dB/10kHz
LOW Filter	-6.5dB/50Hz (6dB/oct.)
HIGH Filter	-11.5dB/10kHz (6dB/oct.)
Equalization Curve	PHONO : RIAA S. T. D.
Loudness Contour	+11.5dB/100Hz, +7dB/10kHz with Volume Control set at -40dB position.
Hum and Noise (IHF)	PHONO More than 75dB AUX More than 90dB

FM TUNER/FM MPX SECTION

Frequency Range	87.5MHz to 108MHz
Usable Sensitivity (IHF)	2.2 μV
Capture Ratio (IHF)	3dB
Selectivity (IHF)	More than 40dB
Image Rejection	More than 50dB (98MHz)
IF Rejection	More than 85dB (90MHz)
Spurious Rejection	More than 80dB (98MHz)
AM Suppression	50dB
Signal-to-Noise Ratio	60dB
Harmonic Distortion	Mono : Less than 0.6% (100% Mod.) Stereo : Less than 0.8% (100% Mod.)
Tuning Indicator	Signal strength type and Center Tuning type
Muting	Switchable to ON-OFF
Stereo Separation	More than 38dB (1kHz)
Sub Carrier Suppression	More than 32dB
Antenna Input	Impedance 300Ω balanced and 75Ω unbalanced.

AM TUNER SECTION

Frequency Range	525kHz to 1,605kHz
Usable Sensitivity (IHF)	15 μV
Selectivity (IHF)	More than 25dB
Image Rejection	More than 45dB (1,000kHz)
IF Rejection	More than 30dB
Signal-to-Noise Ratio	More than 50dB
Antenna	Built-in Ferrite Loopstick Antenna

MISCELLANEOUS

Power Requirements	110V, 120V, 130V, 220V and 240V. (Switchable)
	50 - 60Hz
Power Consumption	330W (Max)
Dimensions (overall)	20in./509mm (width) 6-3/4in./172mm (height) 15-5/8in./377mm (depth)
Weight	Without package 34lb, 5oz/15.6kg With package 40lb, 15oz/18.6kg
Furnished Accessories	FM T-type Antenna 1 Pin Plug 4 Speaker Plug 6 Fuse (1.5A) 1 Fuse (3A) 2 Polishing Cloth 1 Operating Instructions 1

NOTE: Specifications and the design subject to possible modification without notice due-to improvement.

2 • FRONT PANEL FACILITIES

POWER

Push once to switch ON the power, once again to turn it OFF.

SPEAKER SWITCHES

These push-button switches turn the speaker systems ON or OFF.

Depressing the FRONT button will disconnect the speaker systems connected to the speaker sockets CH. 1 and CH. 3. Depressing the REAR button will disconnect the speaker systems connected to the speaker sockets CH. 2 and CH. 4. To return the button from OFF to ON, depress the button once again.

PHONES JACKS

Plug the headphones into FRONT jack to hear in the left and right ears through CH. 1 and CH. 3.

Likewise, plug the headphones into REAR jack to hear in the left and right ears through CH. 2 and CH. 4.

FRONT BASS CONTROL

Controls the bass of channels 1 and 3. Turning the control to the right will increase the tone, and to the left will decrease the tone.

FRONT TREBLE CONTROL

Controls the treble of channels 1 and 3. Use the control in the same way as FRONT BASS CONTROL.

REAR BASS CONTROL

Controls the bass of channels 2 and 4. Use the control in the same way as FRONT BASS CONTROL.

REAR TREBLE CONTROL

Controls the treble of channels 2 and 4. Use the control in the same way as FRONT BASS CONTROL.

FILTERS

LOW: Use this filter to cut out low-frequency interference, such as motor rumbling or hum.

HIGH: Use this filter to cut out high-frequency interference, such as that from fluorescent lights.

LOUDNESS

To listen to quieter sound, set this to the ON position. This emphasizes the low and high notes. For normal listening, set it to the OFF position.

FM MUTING

This switch is used to suppress much noise between FM stations when tuning. In a fringe area, however, this switch should be kept off because it may suppress the desired station signal at the same time.

TUNING INDICATOR

When selecting an AM broadcast, tune so that the dial pointer of the lower meter deflects as far to the right as possible.

For an FM broadcast, use the lower meter in the same way. Precise FM tuning is also possible by adjusting so that the dial pointer of the upper meter is centered.

TUNING KNOB

This knob is used to locate AM or FM stations. Watch the pointer(s) deflection of the tuning indicator for more precise tuning.

VOLUME CONTROL

Controls the output volumes of all four channels simultaneously. Turning the knob to the right will increase the volume, and left will decrease the volume.

MODE SWITCH

2 CH. STEREO 2-channel stereo playback.

QUADRALIZER ... 2-channel stereo program source is to be reproduced as a 4-channel stereo program through the provision of MATRIX or PHASE SHIFT system.

4 CH. STEREO 4-channel stereo playback.

MONO L (CH. 1) ... Input signal for the front left (CH. 1) is to be reproduced through all four speaker systems.

MONO R (CH. 3) ... Input signal for the front right (CH. 3) is to be reproduced through all four speaker systems.

NOTE: MONO L or MONO R position will facilitate level balance adjustment among four channels.

SELECTOR

This switch is used for choosing the program source.

AM AM reception.

FM MONO FM monophonic reception only.

FM AUTO FM reception by automatic switching for either stereo or monophonic program.

PHONO 1 For playing records on a turntable plugged into the PHONO 1 jacks.

PHONO 2 Same as above, for PHONO 2 jacks.

AUX 1 For playing signals fed to the AUX 1 jacks.

AUX 2 Same as above, for AUX 2 jacks.

QUADRALIZER SELECT SWITCH

Select either MATRIX or PHASE SHIFT system.

MATRIX For a 4-channel stereo playback through MATRIX system from 2-channel input source.

PHASE SHIFT Depress the switch for a 4-channel stereo playback through PHASE SHIFT system from 2-channel input source.

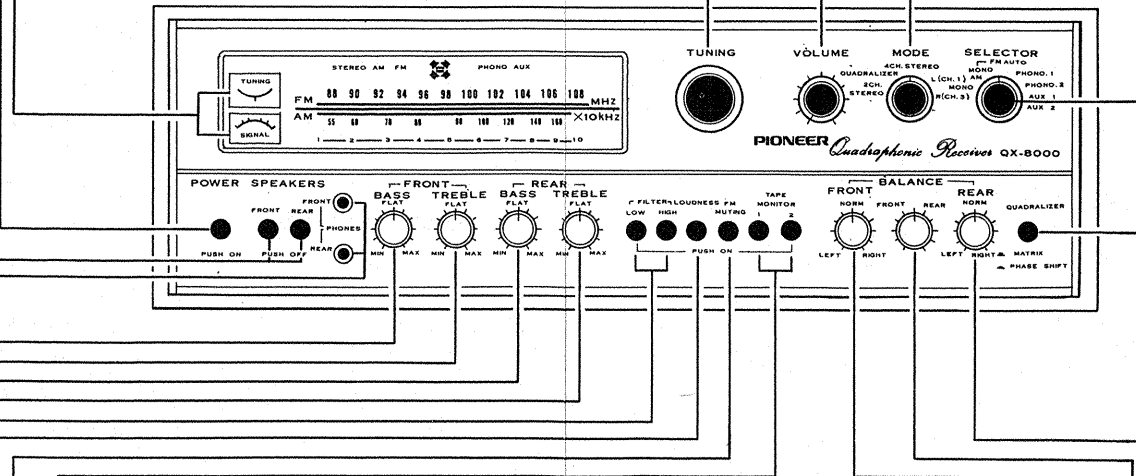

TAPE MONITOR SWITCHES (1 AND 2)

These switches are set to ON for checking the recording conditions or for playback with tape decks.

1. This switch is set to ON for monitoring recording in progress or for playback with a tape deck connected to TAPE 1 MON jacks and TAPE 1 REC jacks.

2. This switch is set to ON for checking the recording conditions or for playback with a tape deck connected to TAPE 2 MON jacks and TAPE 2 REC jacks.

NOTE: For a record playback or listening to broadcasts, leave these switches set to the OFF position. With the switches set to ON, speakers will not operate.

FRONT LEFT-RIGHT BALANCE CONTROL

Controls the level balance of front speaker systems. Turning the control to the right (clockwise) from NORM will increase the sound of the right-side speaker, and turning it to the left (counterclockwise) will increase the sound of the left-side speaker.

FRONT-REAR BALANCE CONTROL

Controls the level balance between the speaker systems in front and rear speaker systems. Turning the control to the right from the center will increase the sounds of the rear side speaker system, and turning it to the left will increase the sounds of the front side speaker system.

REAR LEFT-RIGHT BALANCE CONTROL

Controls the level balance of rear speaker systems. Turning the control to the right (clockwise) from NORM will increase the sound of the right-side speaker, and turning it to the left (counterclockwise) will increase the sound of the left-side speaker.

3 • CONNECTION DIAGRAM

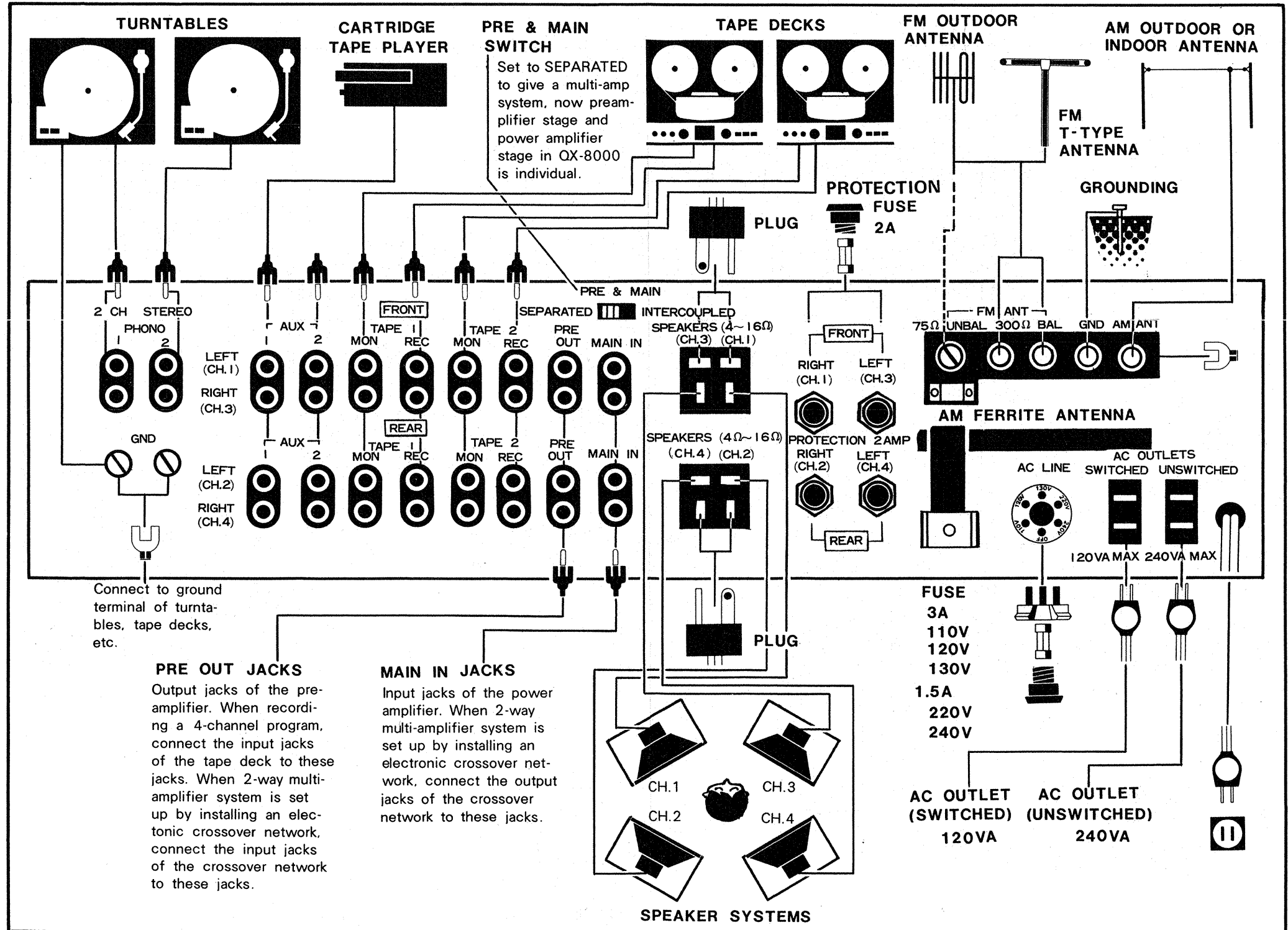

4 • CIRCUIT DESCRIPTION

4.1 BLOCK DIAGRAM

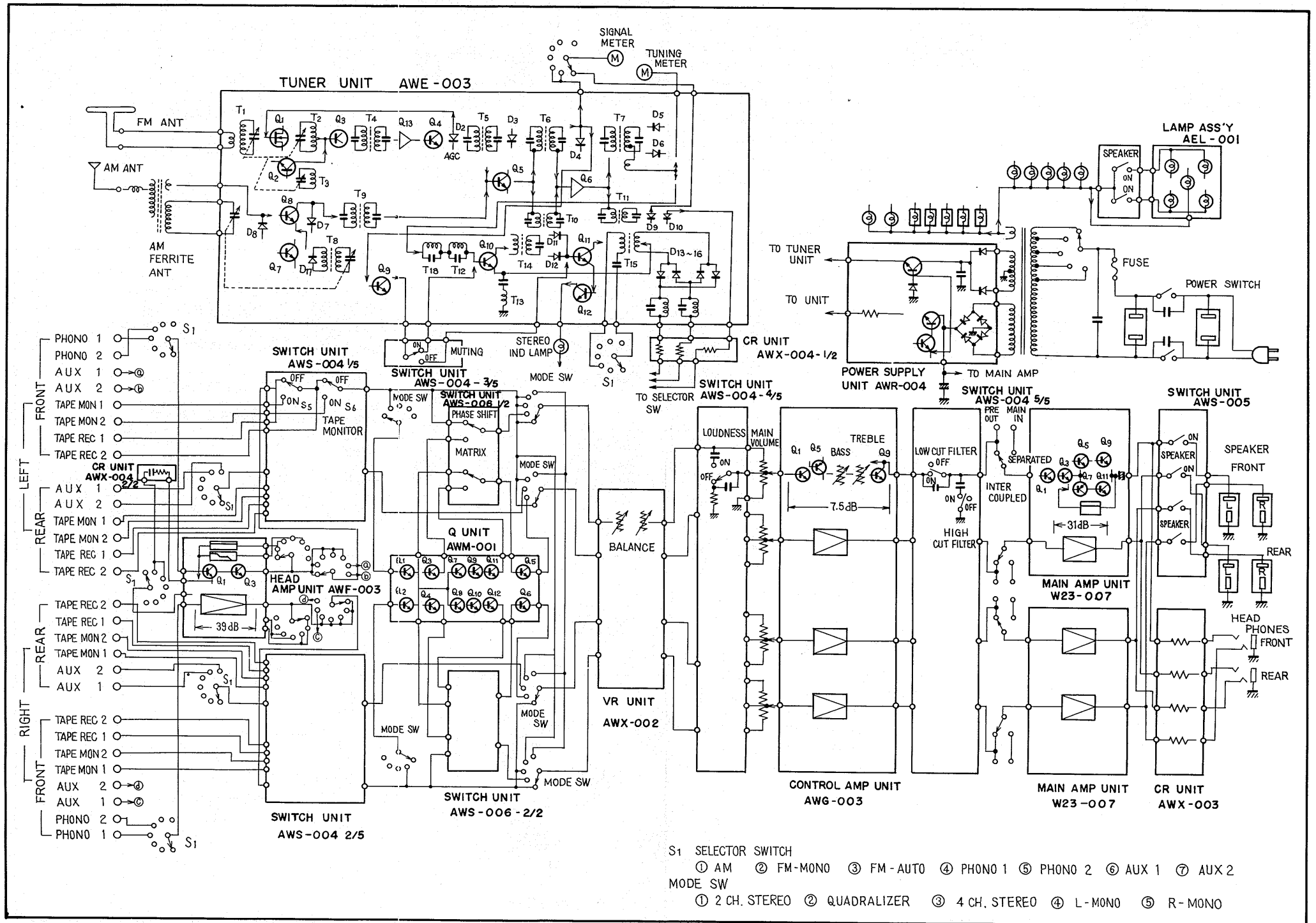

4.2 FM AM UNIT

FM FRONT END

The FM input signal from the FM antenna passes transformer T1 and is fed to the gate of the field effect transistor Q1 where the signal is amplified. Since an FET is employed in the circuit, a high-Q tuning circuit is obtained, providing better image rejection, low noise and excellent cross modulation resistance. The use of the FET balances the bridge circuit consisting of the feedback capacity Crss of Q1, capacitor C6, and transformer T2 to prevent the amplified signal from being fed back to the input side through the Crss, thus assuring stabilized, high gain.

The frequency converter is a split type oscillating circuit consisting of transistors Q2 and Q3, and a 10.7MHz trap circuit of L3 and C9 is provided to the emitter of the Q3 to improve the S/N ratio. The Colpitts type oscillating circuit is employed in the local oscillator and the oscillating frequency is injected into the base of transistor Q3 through C12.

FM IF AMPLIFIER SECTION

This section consists of Q13, Q4, Q5, and Q6. Q13 is a hybrid IC consisting of a transistor and a ceramic filter, for the purpose of improving selectivity. Q6 is a monolithic IC which assures excellent limiter characteristics. Q5 and Q6 also function as an IF amplifier for AM. In the AGC, the signal from the collector of Q4 is rectified by diode D2, and the DC signal is applied to the gate of Q1. Diode D3 on the secondary side of transformer T5 functions as a limiter against large input. The working voltage for the signal strength meter is obtained through D4 on the secondary side of transformer T6. The working voltage for the center tuning meter is obtained by eliminating the 10.7MHz component after ratio detection has been made.

FM MPX SECTION

The signal which has been ratio detected (composite signal including 19kHz pilot signal, L+R, L-R) is applied to the MPX section after its 10.7MHz component has been eliminated by R33 and C42.

- **STEREO RECEPTION**

The composite signal is applied to transistor Q10 after passing the SCA trap consisting of T18, C69 (72kHz) and T12, C71 (67kHz).

Of the composite signal, the 19kHz pilot signal is picked up by T14 which is tuned to 19kHz, and the 19kHz pilot is doubled to 38kHz after rectification by diodes D11 and D12, and then applied to Q11.

Transformer T15, which is tuned to 38kHz, is provided on the collector side of Q11, and the 38kHz pulse becomes a clean 38kHz sine wave switching signal and is applied to the switching circuit. Transistor Q12 is connected to the emitter of Q11, permitting the stereo indicator lamp to turn on and off. On the other hand, Q10 functions as emitter-follower for the L+R signal or L-R signal, providing a signal to the switching circuit. (The emitter of Q10 is provided with a sub-boost circuit consisting of C75 and T13 for improving separation.) The time-switched L and R signals are fed to the audio frequency amplifier section.

- **MONO RECEPTION**

When a mono broadcast is received, there is no 19kHz component in the signal that has been ratio detected, and thus, Q11 and Q12 do not function. Therefore, the stereo indicator lamp does not light, allowing the signal to pass through the diodes of the switching circuit and to the audio frequency amplifier section. Also, if the selector switch is set to FM MONO, the primary side of T15 is opened, disabling Q11. Therefore, a switching signal cannot be formed even if a 19kHz signal is present. The composite L+R signal passes right through the switching circuit.

- **FM AUTO SWITCHING AND MUTING SWITCH**

When the MUTING switch is set to OFF, and the selector switch is set to FM AUTO, the primary side of T15 forms a tank circuit, making a switching signal of 38kHz out of the 19kHz pilot signal and providing this switching signal to the switching circuit. If the input level of the stereo signal from the antenna is low, negative voltage rectified by D4 on the secondary side of T6 is also low. Thus, Q9 is turned on, and the base voltage of Q11 connected to the collector circuit of Q9 becomes zero, not allowing the 38kHz to be amplified. The stereo signal is not time-switched, and reception is monophonic. When the MUTING switch is set to ON, the collector of Q9 is connected to the base of Q10, and thus, when the input from the antenna is low, Q9 is also turned on, eliminating the base voltage of Q10 to turn it off, and thus the ratio detected signal does not appear at the output terminals.

AM TUNER SECTION

This section consists of four transistors Q7, Q8, Q5 and Q6. The AM signal from the ferrite loopstick antenna is applied to Q8, where the signal is converted to IF of 455kHz and picked up at T9. The frequency converter is a split type consisting of Q8 and Q7 for obtaining a more stable IF.

The IF signal, amplified by Q5 and Q6, is detected by D10 on the secondary side of T11. The AGC controls the voltage by applying the detected signal to the base of Q8. Diode D9 is provided to obtain the necessary voltage for the signal meter, and D7 and D8 for guarding against excessive input.

4.3 HEAD AMPLIFIER

The complete head amplifier is contained on the AWF-003 PCB, consisting of two directly coupled circuits. The overall negative feedback loop circuit for equalization is connected from collector of Q3 to emitter of Q1.

Equalization characteristics are: RIAA playback for PHONO, flat response for broadcast reception.

4.4 HIGH LEVEL INPUTS AND CONTROL CIRCUITS

High level inputs such as AUX 1 & 2 are also selected by S1. Input from tape deck and recording output signal (a head amplifier output or a direct output from a high level input) are switched by TAPE MONITOR switches (S5 and S6), respectively. The selected signal then passes to mode switch S2, balance and volume controls.

4.5 CONTROL AMPLIFIER

This stage, consisting of three transistors and tone controls, is embodied on PCB No. AWG-003.

The direct coupled circuitry is used in the top amplifier stage to obtain stable, high impedance under all conditions.

Bass and treble control circuits are connected between collector and base of Q9.

The output from this stage passes to the next filter stage.

4.6 FILTER

The filter stage is embodied on PCB No. AWS-004.

Filter design uses an RC network of 6dB/oct.

4.7 POWER AMPLIFIER CIRCUIT

The power amplifier circuit assembled in the PCB No. W23-007 consists of six transistors (Q1, Q3, Q5, Q7, Q9 and Q11) for each channel. Overall NFB is applied from output to the emitter of Q1, thus improving distortion and frequency response. Transistors Q3, Q5, Q7, Q9 and Q11 are all direct coupled, stabilizing the circuit by applying NFB in both AC and DC. The thermistor against fluctuations in the ambient temperature stabilizes temperature characteristics.

4.8 POWER SUPPLY CIRCUIT

Q1 and Q2 are voltage regulators, supplying low-ripple rectified current to the audio amplifier section.

The other regulated voltage for the tuner section is obtained from other power transformer taps via a full-wave rectifier through voltage regulator Q3. All parts except the filter capacitor and power transformer are located on PCB No. AWR-004.

4.9 Q UNIT

The purpose of this unit is to convert 2-channel signals into 4-channel signals. Two modes of operation can be selected with the MODE and QUADRALIZER switches.

• MATRIX OPERATION

With the MODE switch in position QUADRALIZER, and the QUADRALIZER switch in position MATRIX, the Q unit functions as a circuit shown in Fig. 1. The L signal is applied to the base of Q1, the R signal to the base of Q2. Since resistances of different values are connected to the collectors and emitters of Q1 and Q2, the emitter and collector output levels are of course different, too. Channel correspondences: CH.1 ·· FRONT LEFT: CH.2 ·· REAR LEFT: CH.3 ·· FRONT RIGHT: CH.4 ·· REAR RIGHT.

R13 and R14 provide a combined 2L + R signal, which is the CH. 1 signal. R17 and R18 provide a 2L-R difference signal which is the CH. 2 signal. R15 and R16 provide a 2R + L signal which is the CH. 3 signal.

R19 and R20 provide a 2R-L difference signal which is the CH. 4 signal.

This function is called "MATRIX" operation.

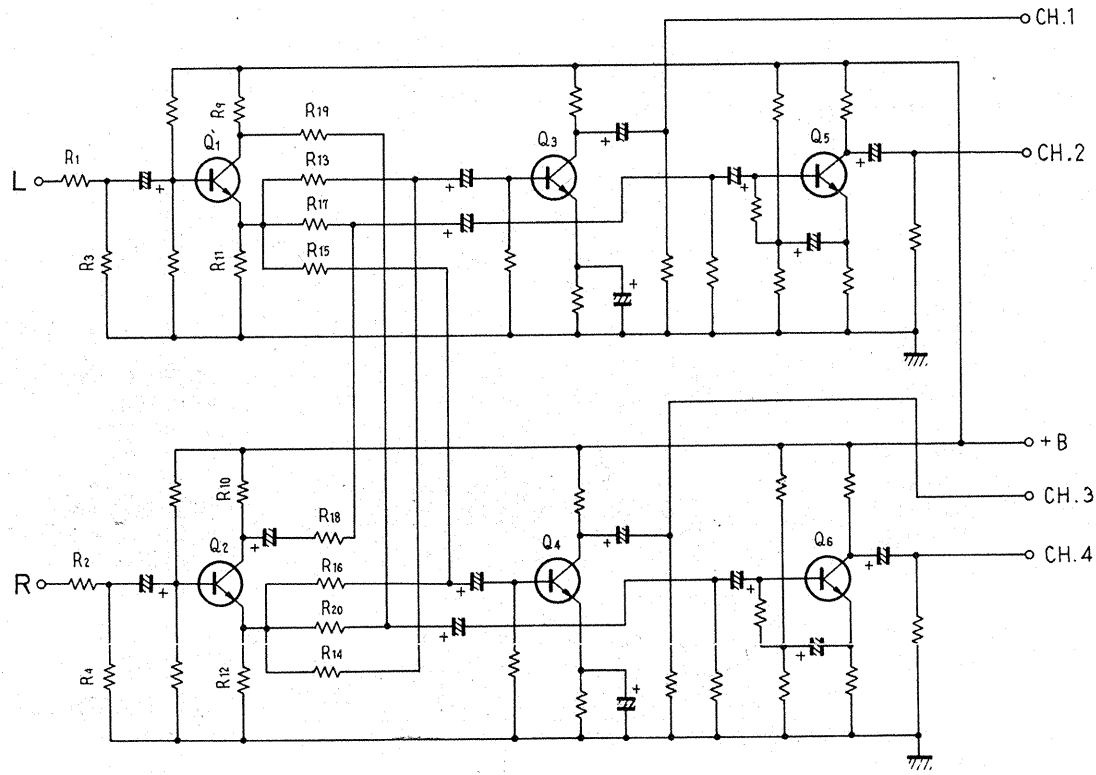

Fig. 1

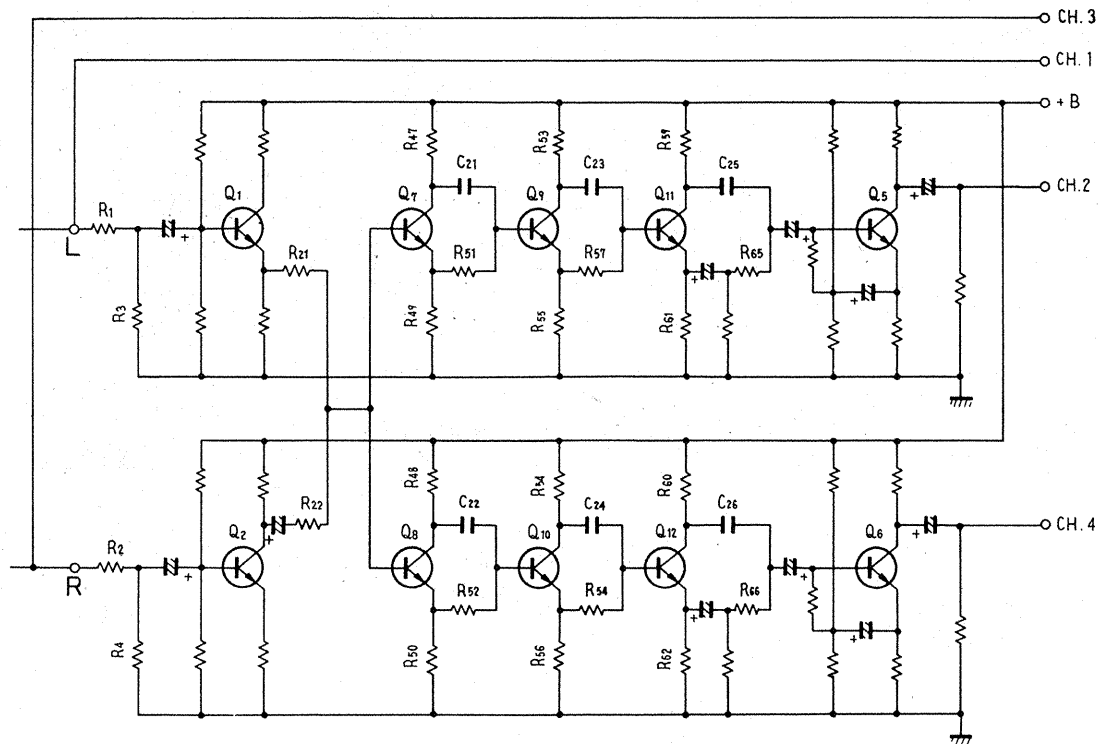

Fig. 2

As the input signal has been divided before it enters the matrix circuit (by the ratio of R1 and R3, which makes the signal about 1/2 its original level), it must be amplified again before it is taken out. Consequently, overall gain is approx. 0dB (unity gain), which means that the matrix circuit does not affect the volume.

● PHASE SHIFT OPERATION

With the MODE switch in position QUADRALIZER, and the QUADRALIZER switch in position PHASE SHIFT, the Q unit functions as a circuit shown in Fig. 2.

The L input signal is applied to the base of Q1, the R signal to the base of Q2. By combining the outputs of the Q1 emitter and the Q2 collector, an L-R signal is obtained, which is then supplied to the bases of Q7 and Q8.

The Q7-to-Q12 stretch is called the "phase shifter." Each of these stages has a slightly different constant. The resistances, however, are the same in each stage, so that the same voltage is present at each of the resistor terminals. One of these stages is shown in Fig. 3 and in the equivalent circuit diagram in Fig. 4. Conditions prevailing here include $rg_1 = rg_2$ and $|e_1| = |e_2|$ and $rg_2 \ll R \ll Z_1$, and appropriate values are chosen to fulfill these conditions.

At low signal frequencies, the reactance of C becomes very large in relation to the value of R, and therefore the voltage across Z1 is divided according to the ratio between R and Z1. This actually means that, because Z1 is very large in relation to R, e2 is practically added to Z1.

Reversely, if the signal frequency is high, the reactance of C becomes very small in relation to the value of R, whereby the voltage across Z1 becomes practically equal to e1.

However, as e1 and e2 differ only in phase, not in |voltage|, the signal amplitude remains constant even though the frequency may change. A phase shift of 0° to 180°, depending upon signal frequency, occurs between input and output. As each phase shifter circuit has a defined time constant and can therefore affect only a limited part of the frequency range, several such phase shifters are being used in order to cover the entire audio band.

Moreover, a second series of 3 such phase shifters is incorporated, with time constants calculated in such a way that the resultant phase shift differs by a constant degree from the phase shift effected by the first series. This means that two phase-delayed outputs are obtained, with a constant additional 90° phase shift between them.

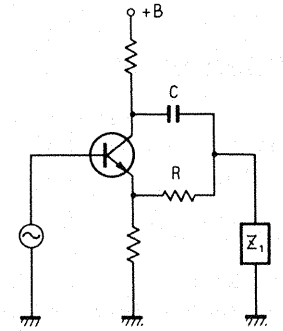

Fig. 3

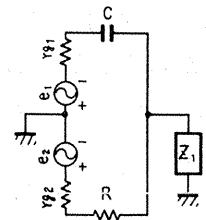

Fig. 4

PHASE SHIFT CHARACTERISTIC

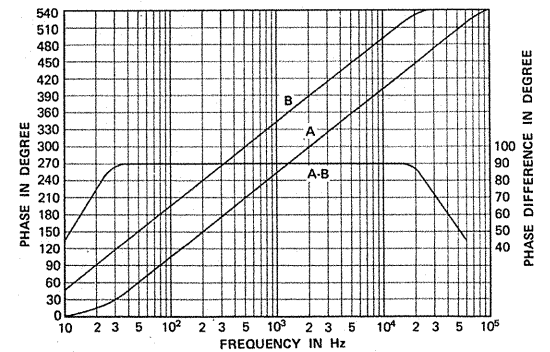

Fig. 5

5 • DISASSEMBLY

5.1 WOODEN CASE

Remove the 4 screws from the bottom of the wooden case. Pull the case backward off the receiver housing.

5.2 FRONT PANEL

Pull off all knobs, then remove nuts and washers from shafts and remove 4 screws from top and bottom of front panel as illustrated in Fig. 6. The front panel can now be removed.

5.3 BOTTOM PLATE

The bottom plate can be removed after loosening the 13 screws.

● Numbers indicate order of disassembly.

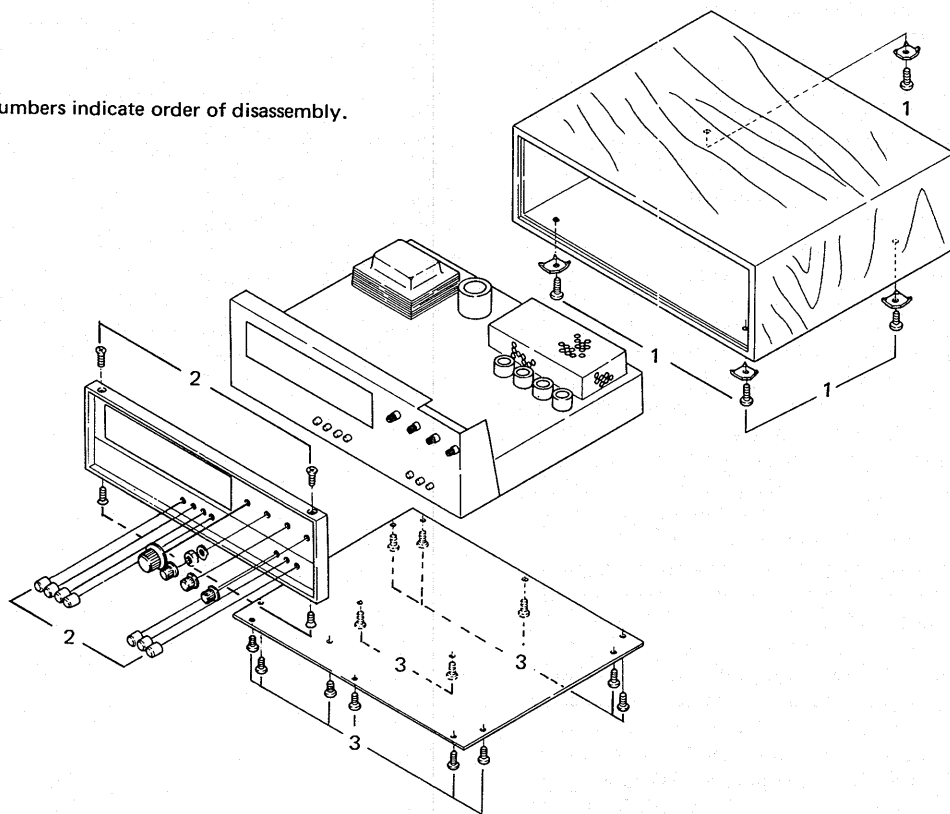

5.4 PARTS AND PCB LOCATION

TOP VIEW

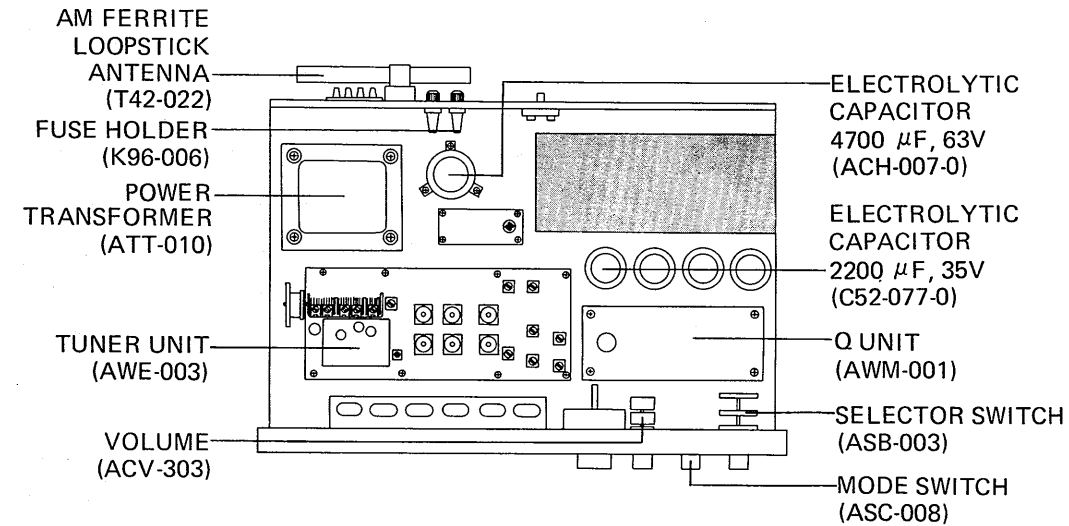

BOTTOM VIEW

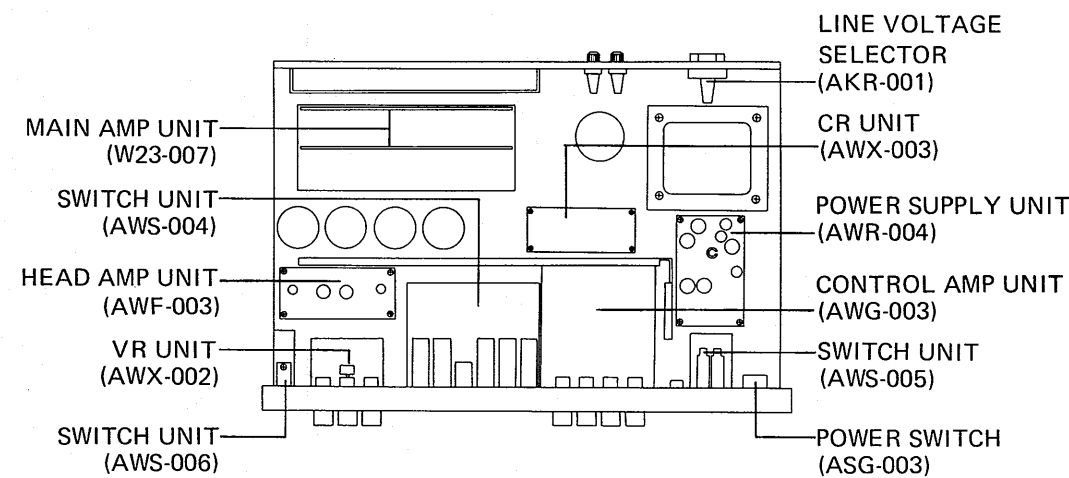

Fig. 6

6 • ALIGNMENT PROCEDURE

Carry out the alignments in the following order:

1. FM IF alignment
2. AM IF alignment
3. FM tracking alignment
4. AM tracking alignment
5. FM MPX decoder circuit alignment

6.1 FM IF ALIGNMENT

- a) Connect a $0.01\mu\text{F}$ capacitor between TP1 and ground before the alignment.
- b) Connect a $220\text{k}\Omega$ resistor in series with the vertical input terminals of the oscilloscope (Fig. 7).
- c) Remove the capacitor ($4.7\mu\text{F}$) from terminal 28 before the alignment.
- d) Turn the selector switch to FM MONO.
- e) Turn the tuning knob to the right to set dial at high end of scale.
- f) Connect the output leads of the sweep generator to the FM antenna terminals (Fig. 7).
- g) Connect the vertical oscilloscope input to the FM meter output terminal 18. When connecting to the FM meter terminal, disconnect the meter lead, then terminate $4.7\text{k}\Omega$ between terminal 18 and ground.
- h) Set the output level of the sweep generator to 60dB.
- i) Adjust the FM IFT cores (T4, T5, T6) as shown in Fig. 7.
- j) Set the output level of the sweep generator to 100dB, then keep the top of the pattern flat and check that the tuning center frequency does not drift when a high level input (100dB) is supplied to the FM antenna terminals. If it drifts, repeat steps (h) and (i).
- k) Disconnect the vertical input of oscilloscope from the FM meter output terminal, reconnect to TP1 (Fig. 8).
- l) Observe the S-curve pattern when adjusting the cores of the FM IFT T7, (Linearity is improved by the primary core; symmetry by the secondary core.) (Fig. 8).
- m) Disconnect the $0.01\mu\text{F}$ capacitor from TP1 after the alignment has been completed.
- n) Connect the capacitor ($4.7\mu\text{F}$) to terminal 28 after the alignment has been completed.

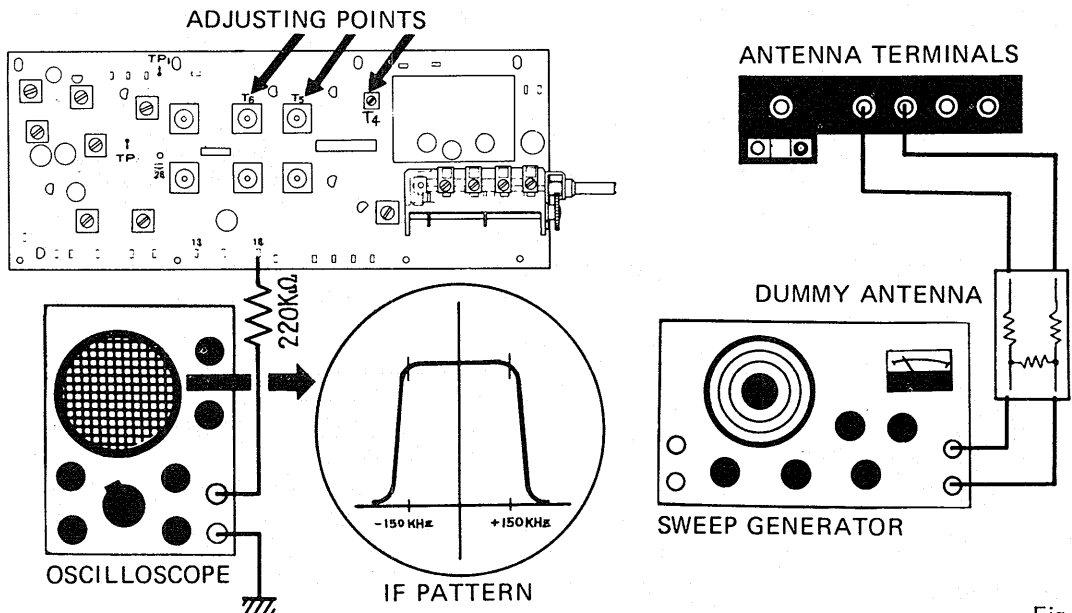

Fig. 7

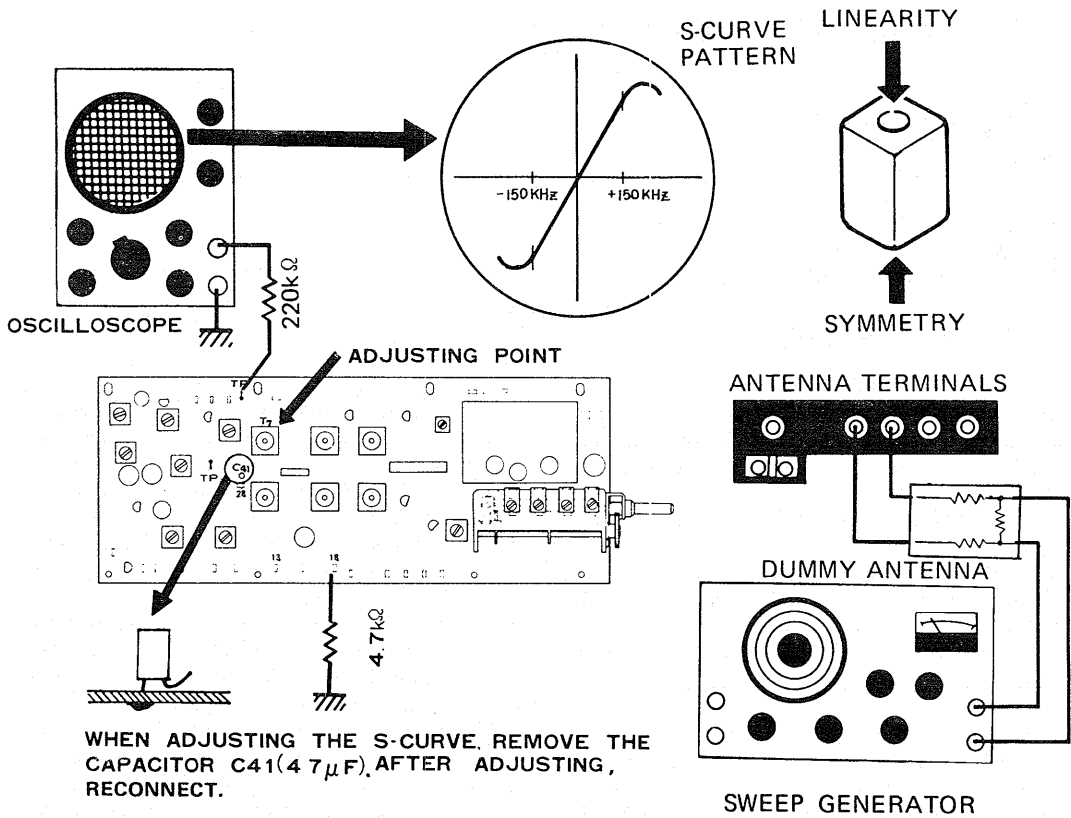

Fig. 8

6-2 AM IF ALIGNMENT

- Turn the selector switch to AM.
- Connect the output leads of the sweep generator to the AM antenna terminal.
- Connect the vertical input leads of the oscilloscope to the AM detector output terminal 13.
- Set the output level of the sweep generator to 40dB.
- Adjust the AM IFT cores (T9, T10, T11) as shown in Fig. 9. Make the pattern symmetrical, with its peak on the oscilloscope screen grid.

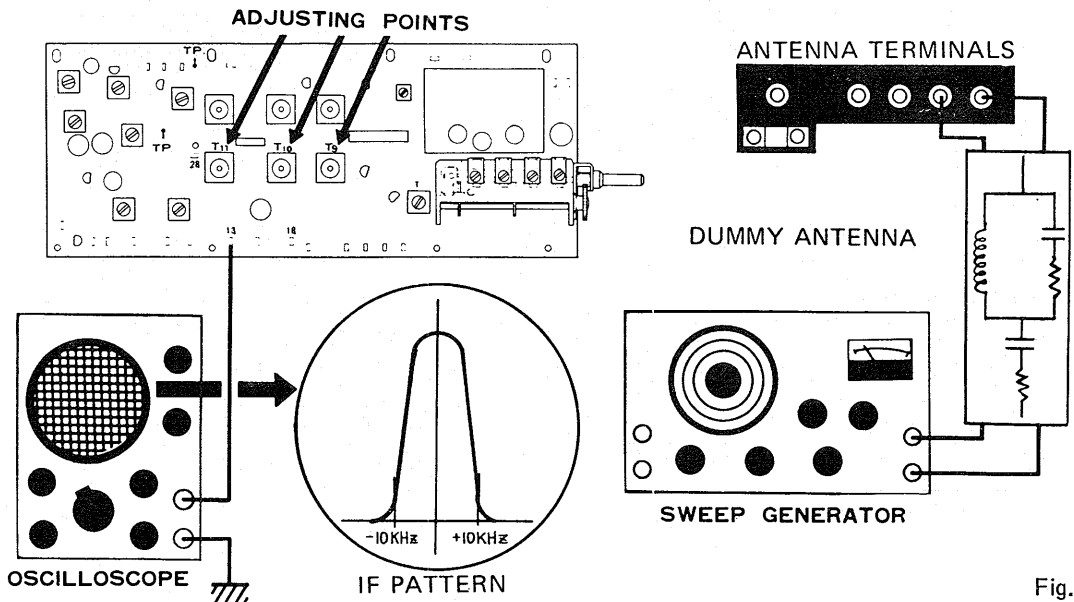

Fig. 9

6-3 FM TRACKING ALIGNMENT

- a) Turn the selector switch to FM MONO.
- b) Connect the output leads of the FM signal generator to the FM antenna terminals.
- c) Set the FM signal generator to modulation 400Hz, 100% and output level 15dB, frequency 90MHz; also set receiver dial at 90MHz.
- d) Connect the VTVM and oscilloscope (in parallel) to the TAPE REC terminal.
- e) Observing the output level on the VTVM, adjust the following cores for maximum reading on the meter.
 - T3 Oscillator circuit
 - T1 Antenna coil circuit
 - T2 RF circuit
- f) Set the frequency of the FM signal generator and the tuner dial to 106MHz.
- g) Adjust as follows:
 - Trimmer capacitor CT3: Oscillator circuit
 - Trimmer capacitor CT1: Antenna circuit
 - Trimmer capacitor CT2: RF circuit
- h) Repeat steps (e) to (g) several times.
- i) After the alignment, lock the trimmer capacitor with paint.

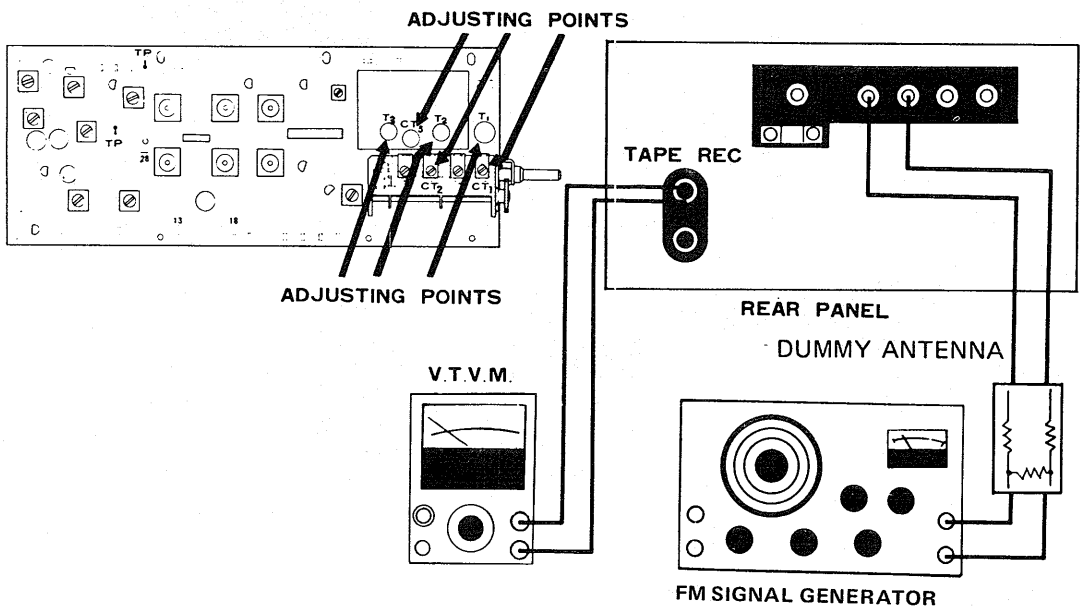

Fig. 10

6-4 CHECKING OF MUTING FUNCTION

- a) Connect the output leads of the FM signal generator to the FM antenna terminals.
 - b) Connect the vertical input leads of the oscilloscope to the TAPE REC terminal.
 - c) Set the output level of the FM signal generator to 16dB and turn the muting switch on, then check the muting function on the scope.
- The muting function is designed to operate below about 16dB input.

6-5 AM TRACKING ALIGNMENT

- a) Turn the selector switch to AM.
- b) Connect the AM signal generator to the AM antenna terminal (Fig. 11).
- c) Set the AM signal generator to modulation 400Hz, 30%, output level 30dB, frequency 600kHz. Set the receiver dial at 600kHz.
- d) Connect the VTVM and oscilloscope (in parallel) to the TAPE REC terminal.
- e) Observing the output level on the VTVM, adjust the following cores for maximum reading.
 T8 Oscillator circuit
 Ferrite loopstick antenna: Antenna circuit

- f) Set the AM signal generator and the tuner to 1,400kHz.
- g) Observing the output level on the VTVM, adjust the following cores for maximum reading.
 CT5 Oscillator circuit
 CT4 Antenna circuit
- h) Repeat alignments (c) to (g) several times.
- i) After these alignments, lock the trimmer capacitor with paint.

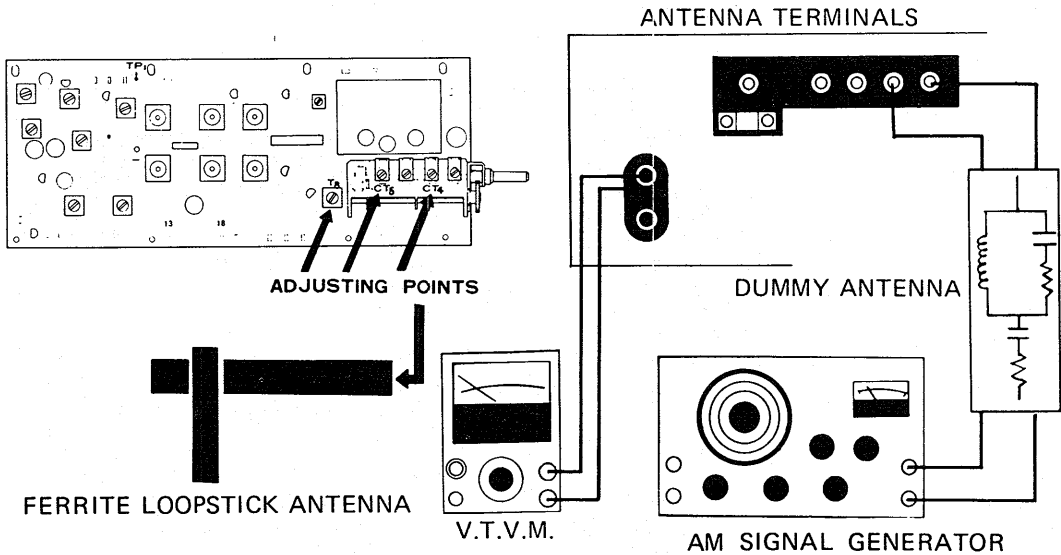

Fig. 11

6-6 MPX DECODER ALIGNMENT

- a) Modulate the FM signal generator output by FM MPX modulator.
- b) Turn the selector switch to FM AUTO.
- c) Connect the FM signal generator to the FM antenna terminals.
- d) Set the FM MPX modulator to modulation: main 1kHz (L+R) 60%, pilot 8 ~ 10%.
- e) Set the output level of the FM signal generator to 60dB.
- f) Turn the tuning knob to maximum reading on the signal meter.
- g) Set the modulation of the FM MPX modulator to pilot only.

- h) Connect the oscilloscope to TP2.
- i) Adjust the transformers (T13, T14, T15) until the output level of the 19kHz becomes maximum on the scope.
- j) Set the FM MPX modulator to pilot with L or R signal.
- k) Connect the dual-trace oscilloscope and VTVM to the TAPE TEC terminals.
- l) Adjust the semi-fixed potentiometer on the CR unit printed circuit board until the output level of the L or R signal becomes maximum on the scope.

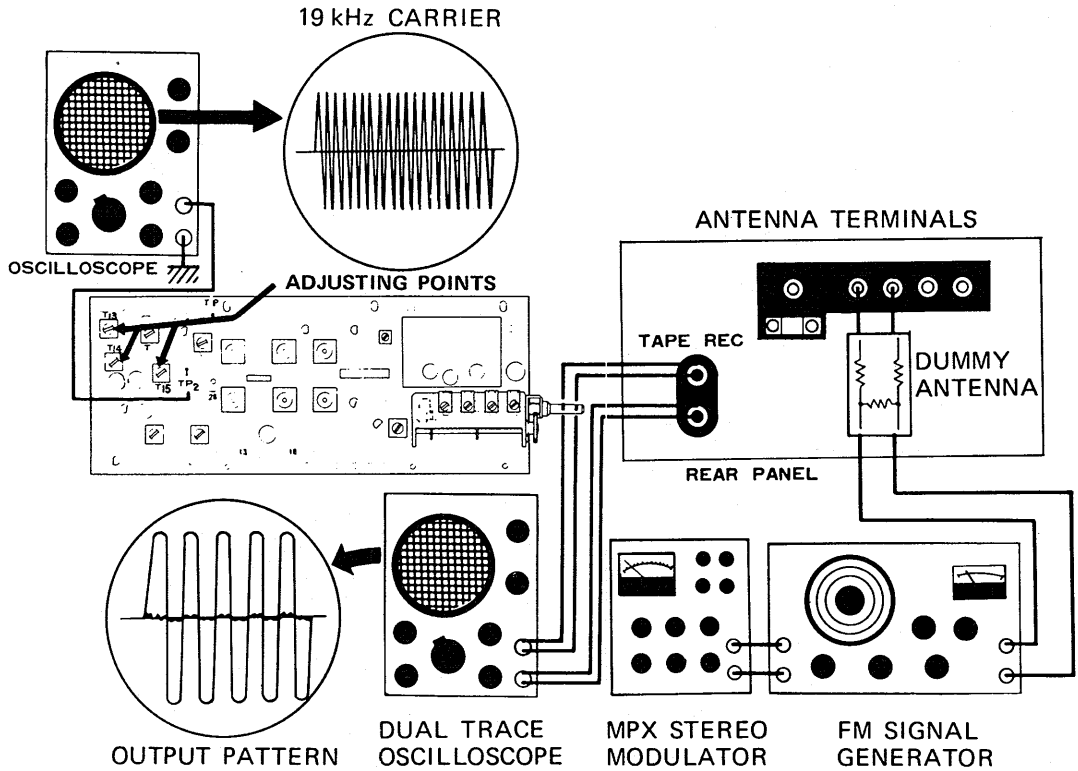

Fig. 12

6-7 CHECKING THE SCA FILTER

- a) Connect the FM signal generator to the FM antenna terminals.
- b) Turn the selector switch to FM AUTO.
- c) Modulate the FM signal generator connected to the audio generator, check that the frequency response shows troughs at around 67kHz and 72kHz.

6-3 CHECKING THE STEREO INDICATOR

- a) Connect the FM signal generator to the FM antenna terminals.
- b) Turn the selector switch to FM AUTO.
- c) Modulate the FM signal generator connected to the FM MPX modulator, and set the FM MPX modulator pilot on. Check that the stereo indicator lamp goes on. Then set the FM MPX modulator to pilot off, and check that the stereo indicator lamp goes out.

7 • DIAL CORD STRINGING

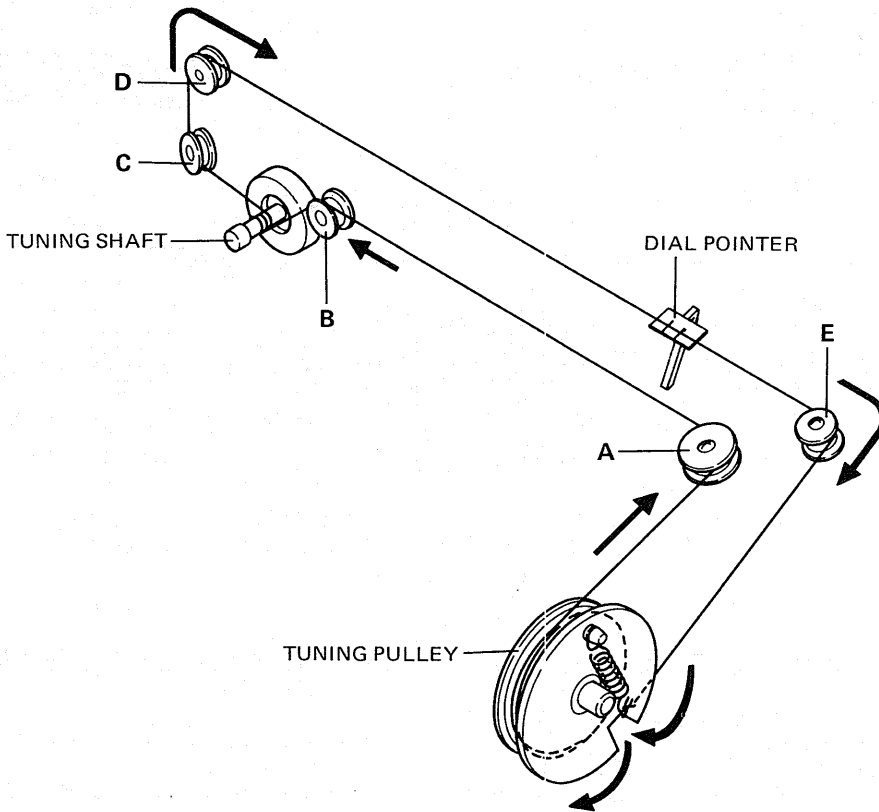
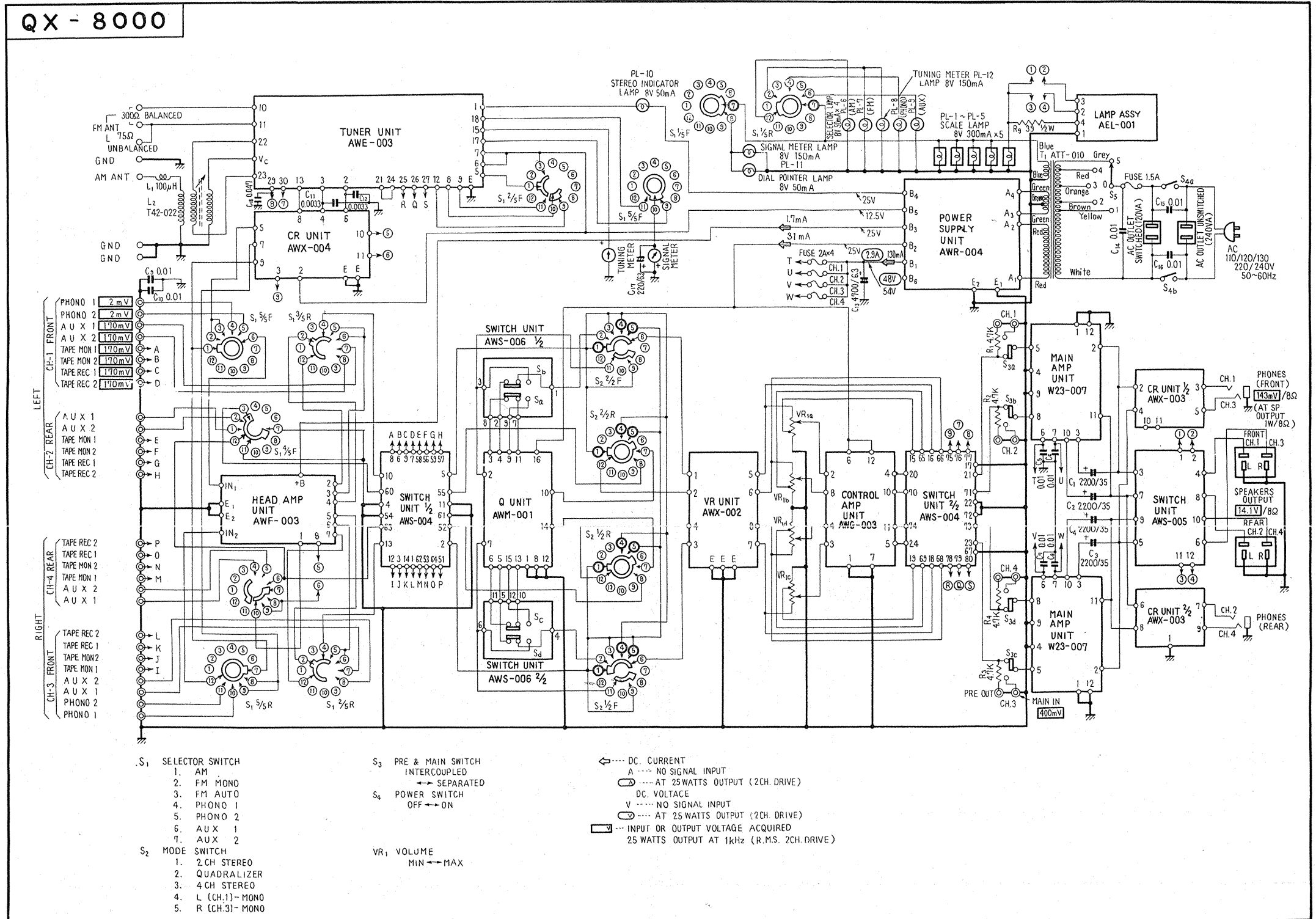

Fig. 13

1. Set the tuning capacitor to maximum capacitance.
2. Tie one end of string on tuning pulley.
3. Wind string $\frac{1}{2}$ turn around tuning pulley.
4. Pull string around small pulleys A and B, then wind 3 turns around tuning shaft.
5. Lead string around small pulleys C and D, then fasten string to dial pointer.
6. Lead string around small pulley E, then wind string 1 turn around tuning pulley.
7. Finally, tie end of string to remaining side of spring on tuning pulley.
8. Tune receiver to low end. Fasten dial pointer to string so that it indicates low end on dial scale.

8 • SCHEMATIC DIAGRAMS AND PCB PATTERNS

UNIT CONNECTION DIAGRAM



TUNER UNIT (AWE-003)

TUNER UNIT
AWE-003

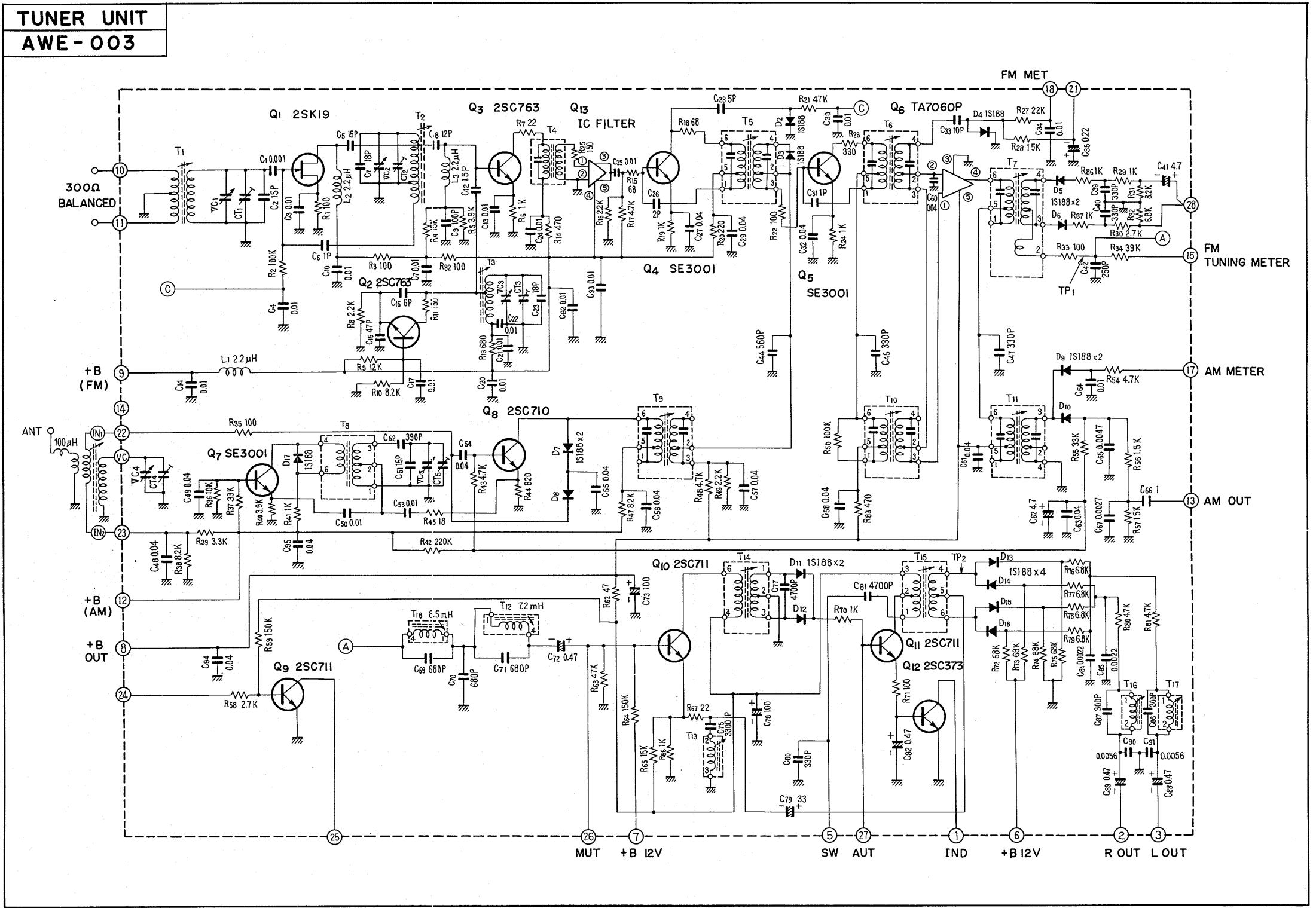

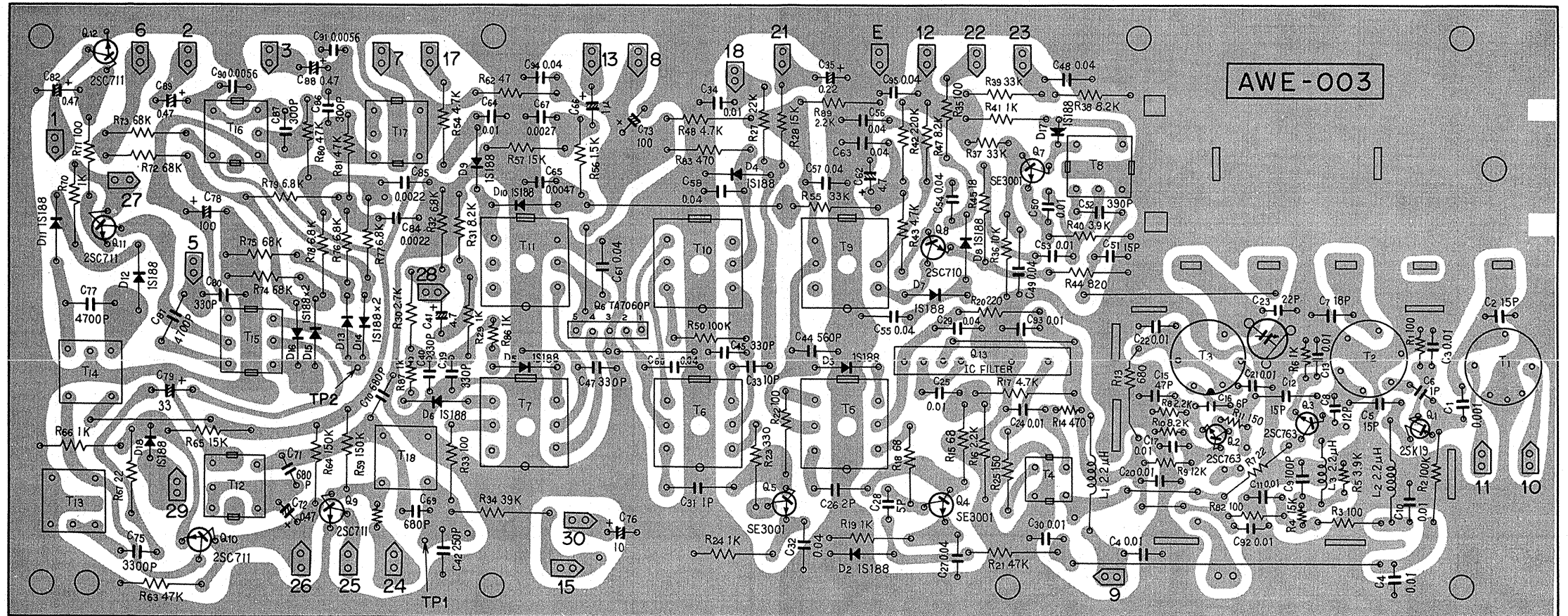

HEAD AMP UNIT (AWF-003)

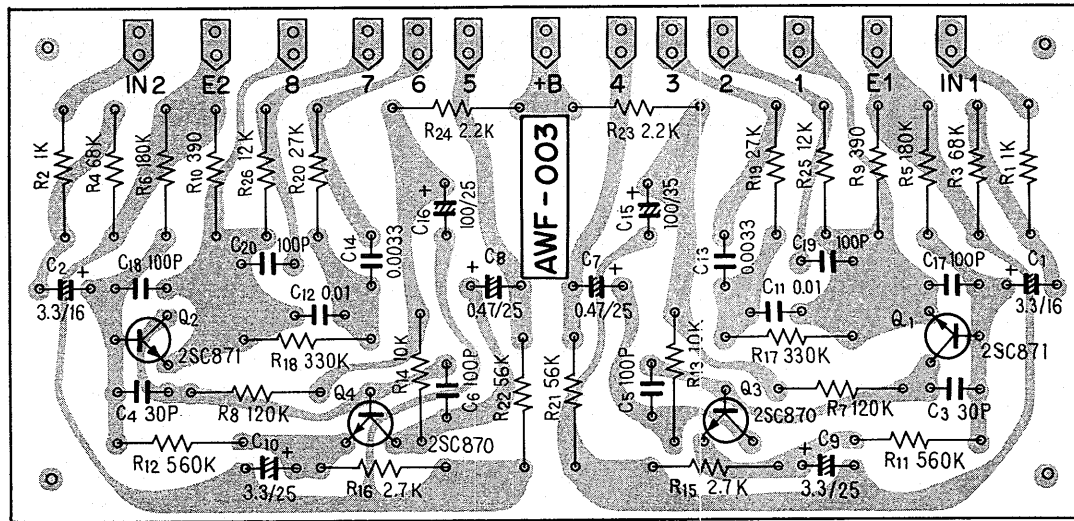
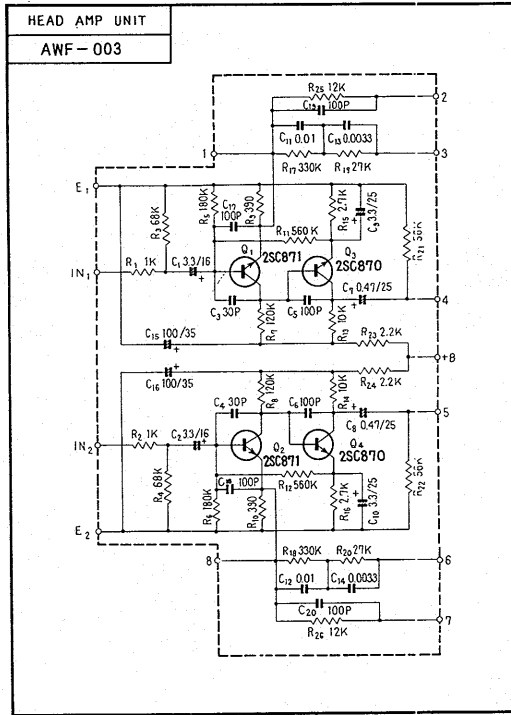

Q UNIT (AWM-001)

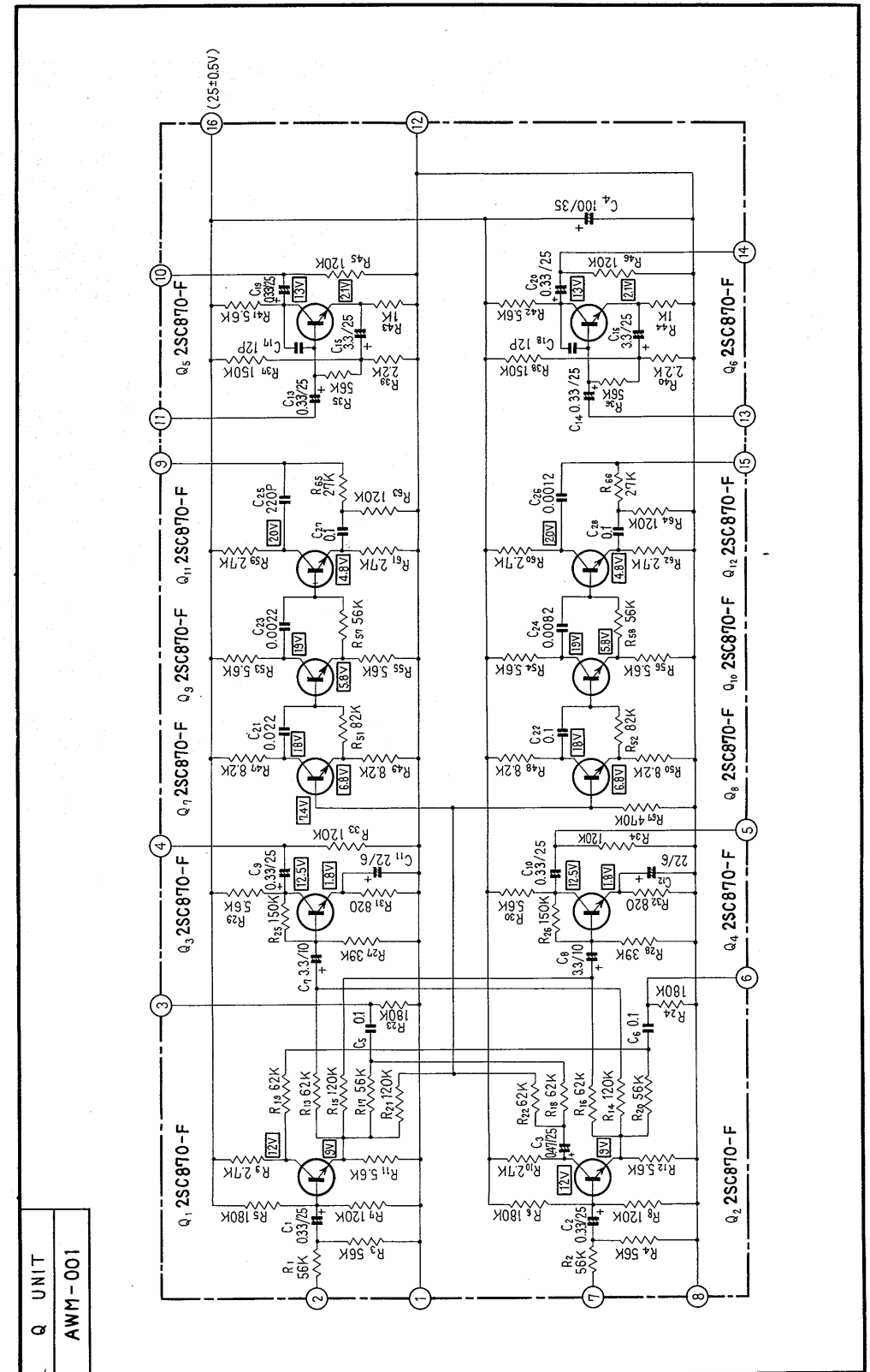

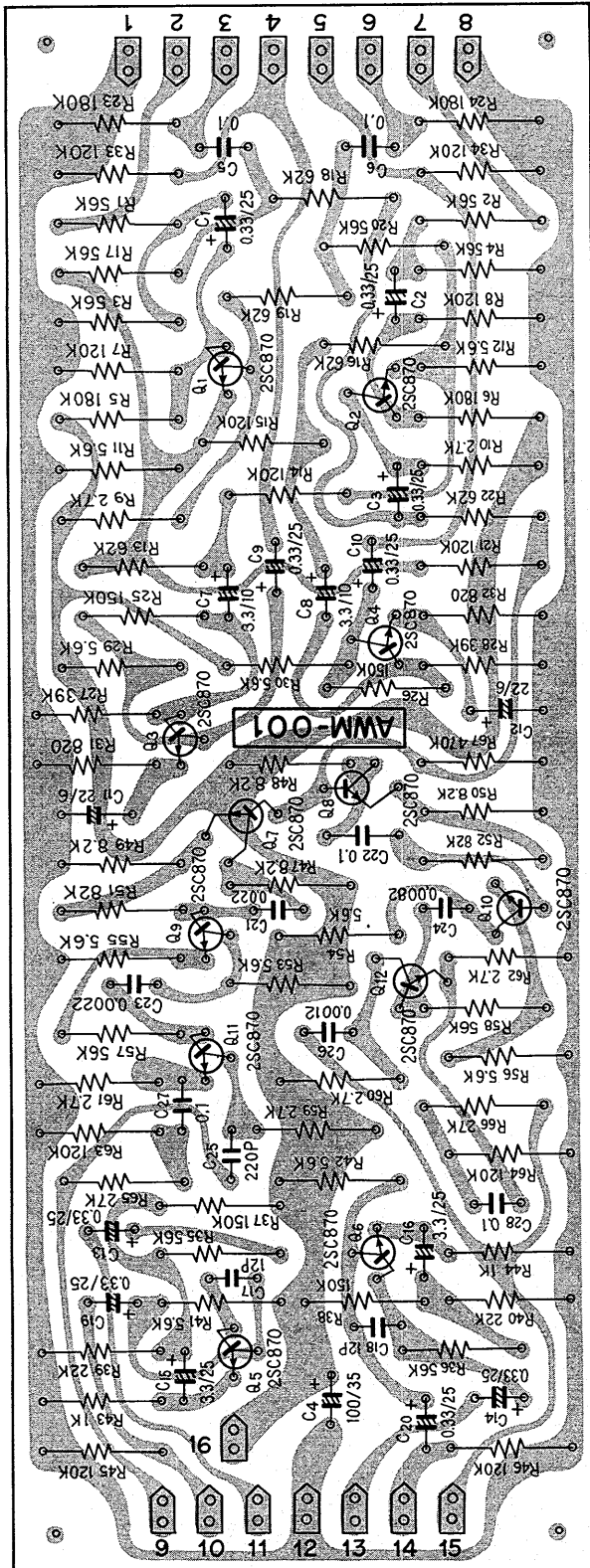

CONTROL AMP UNIT (AWG-003)

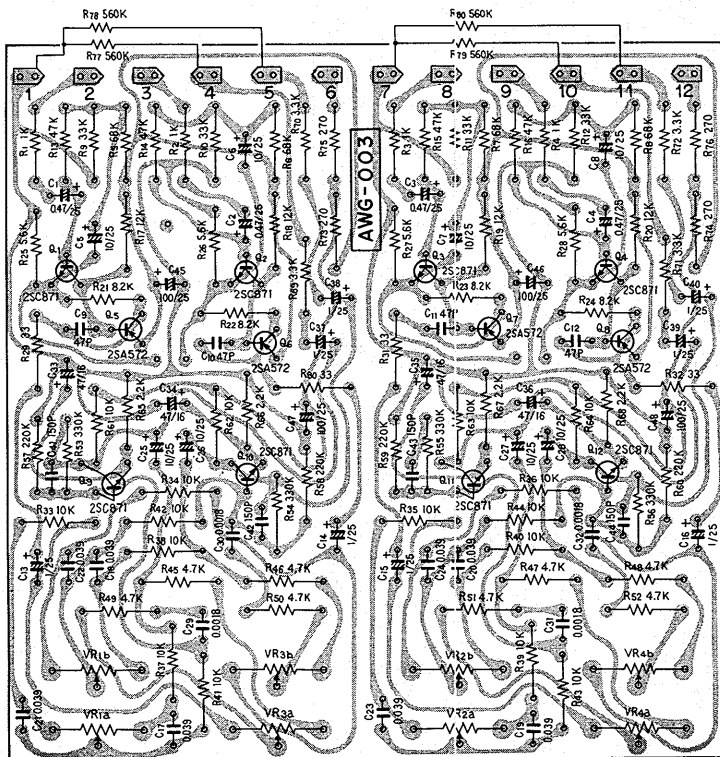
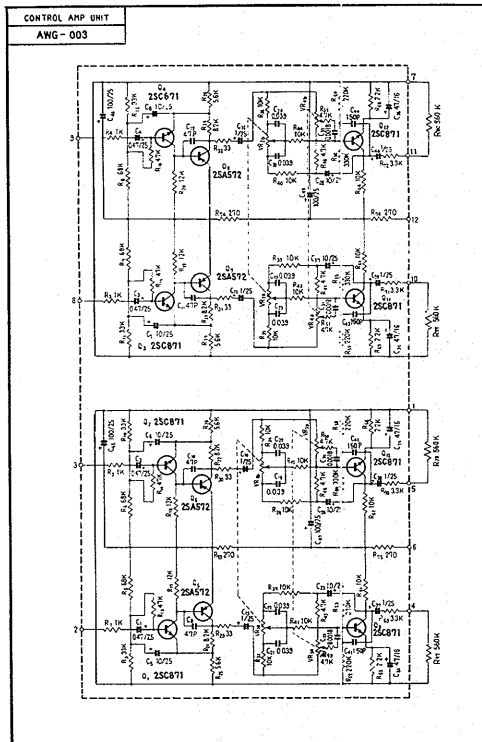

MAIN AMP UNIT (W23-007)

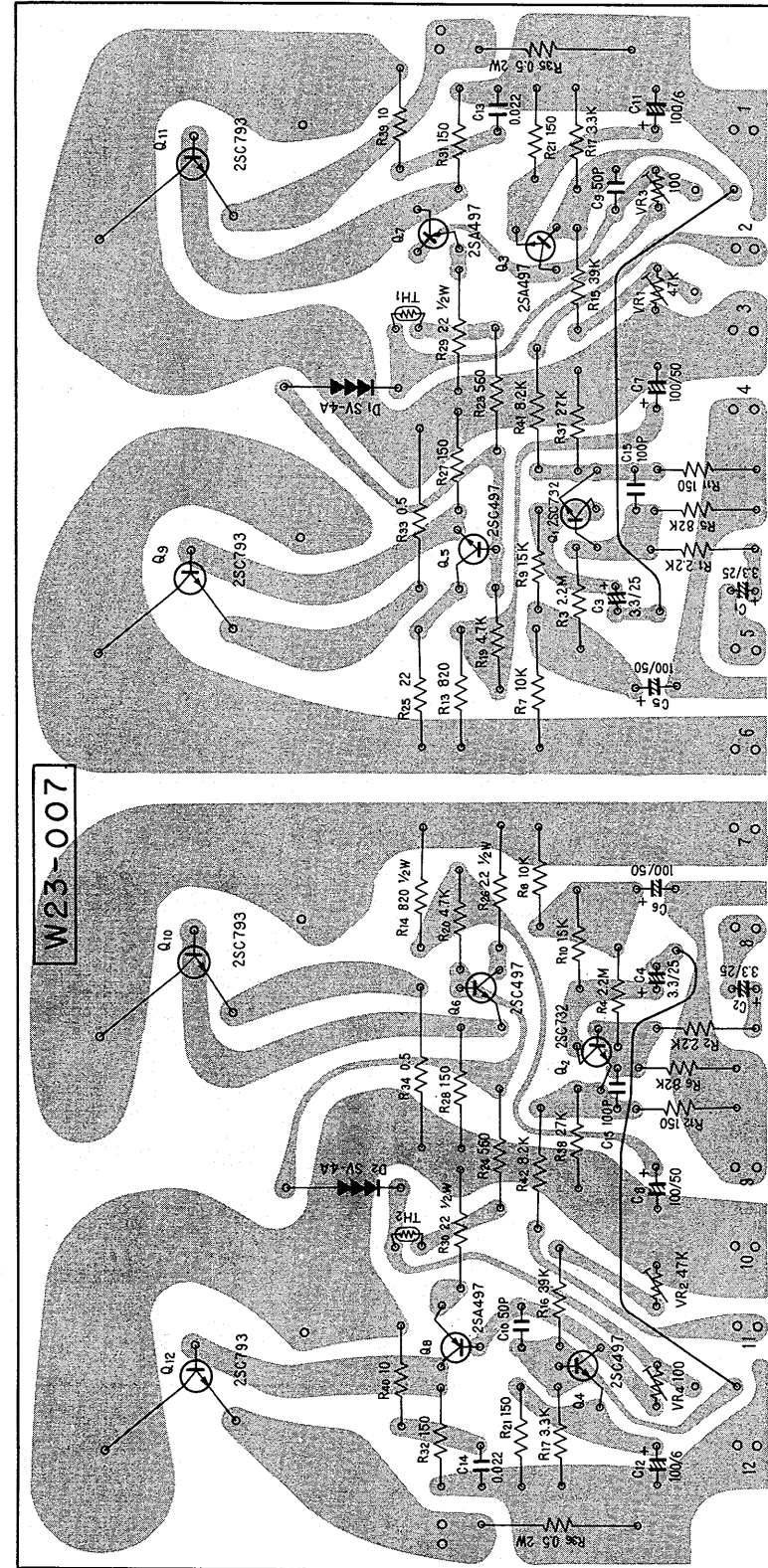
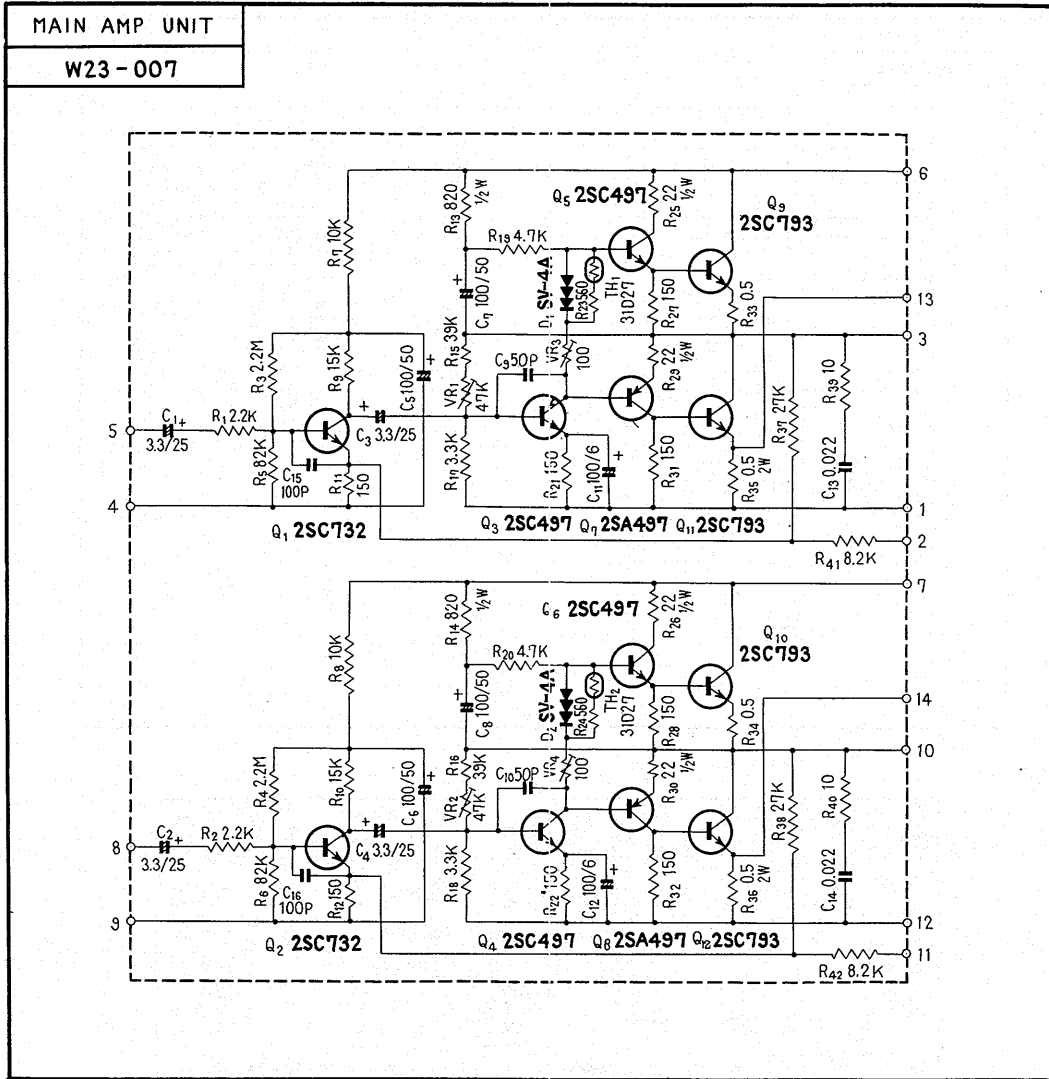

POWER SUPPLY UNIT (AWR-004)

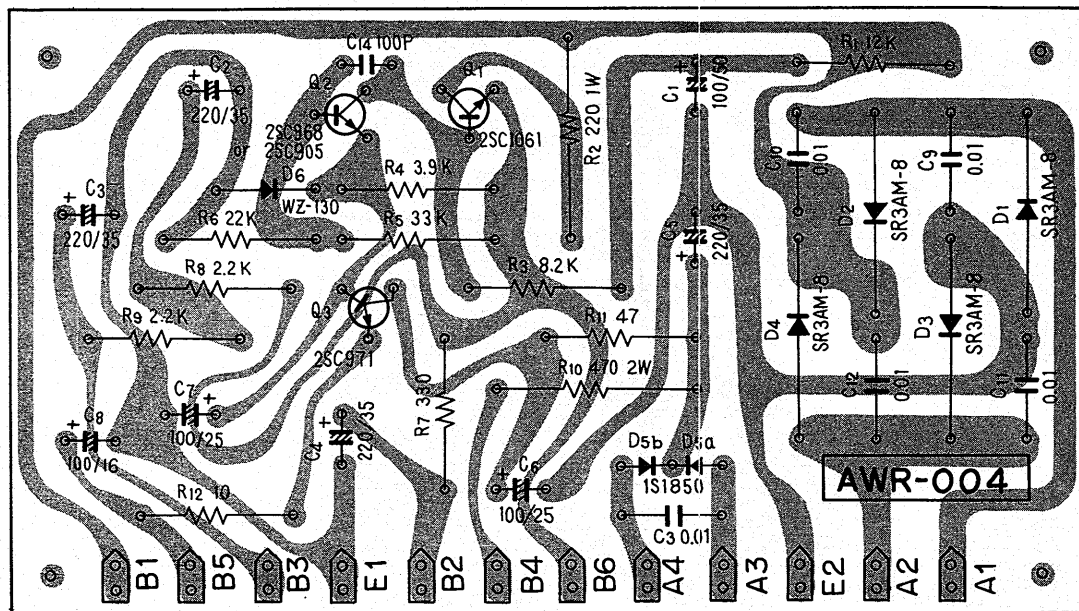
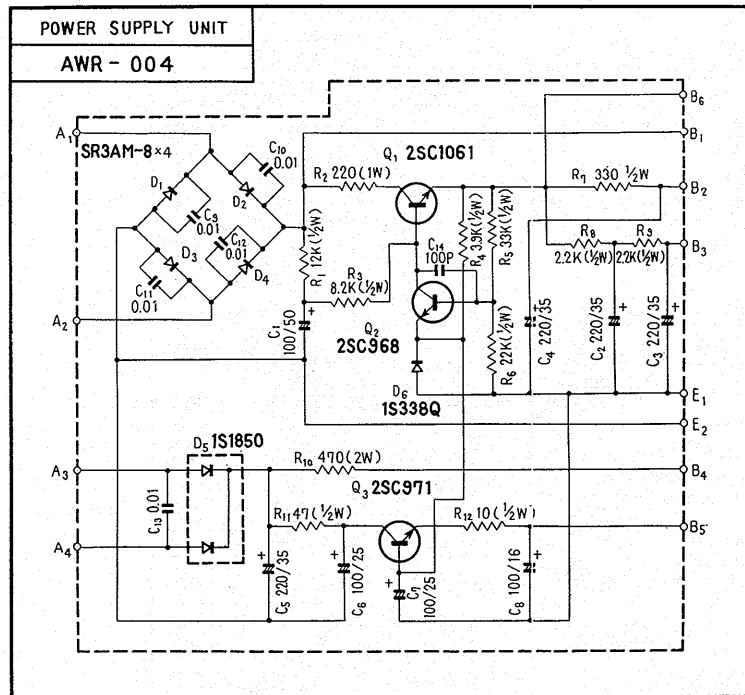

SWITCH UNIT (AWS-004)

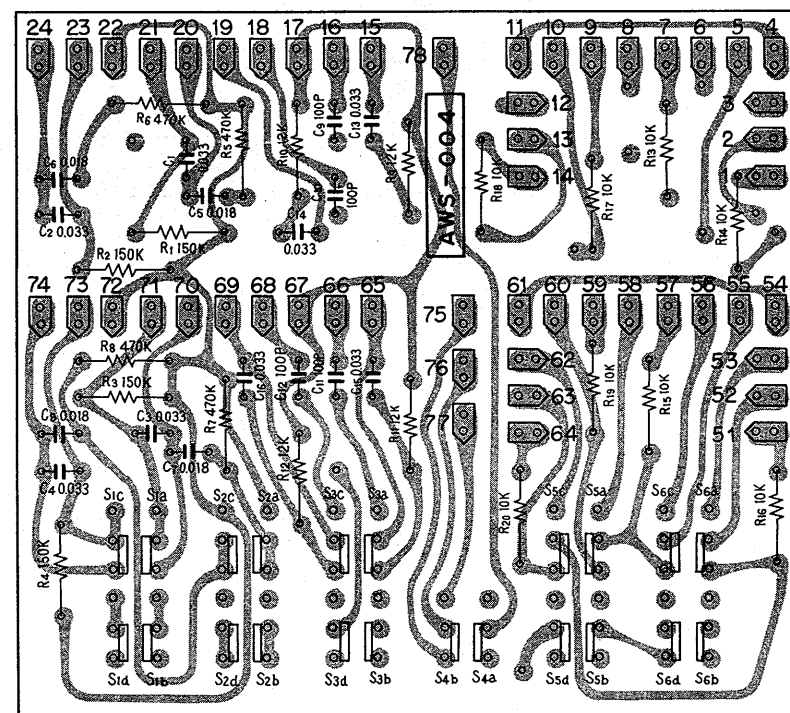
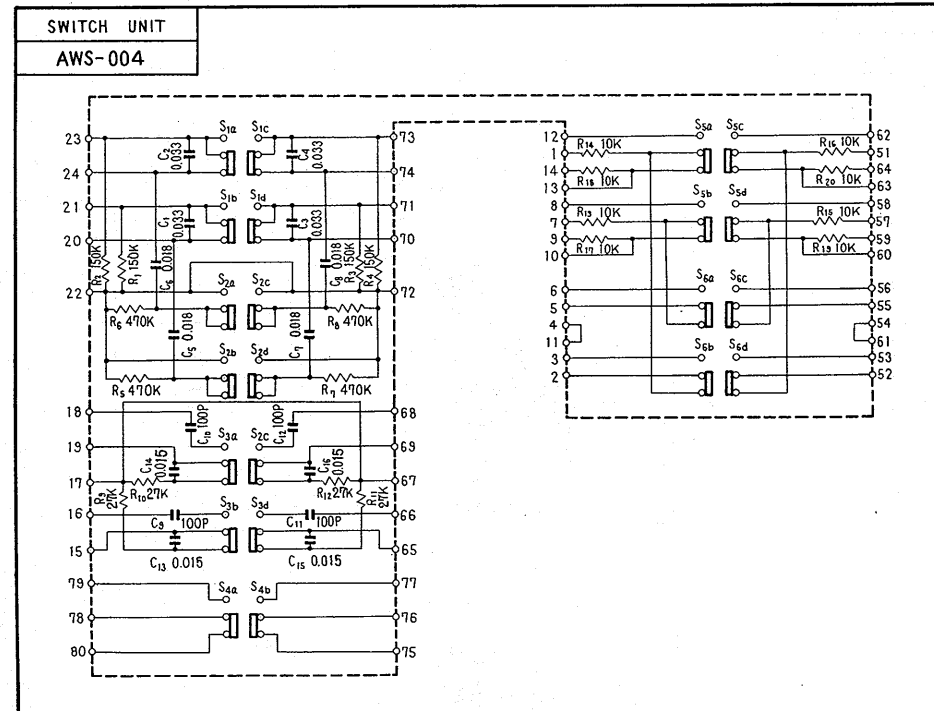

SWITCH UNIT (AWS-005)

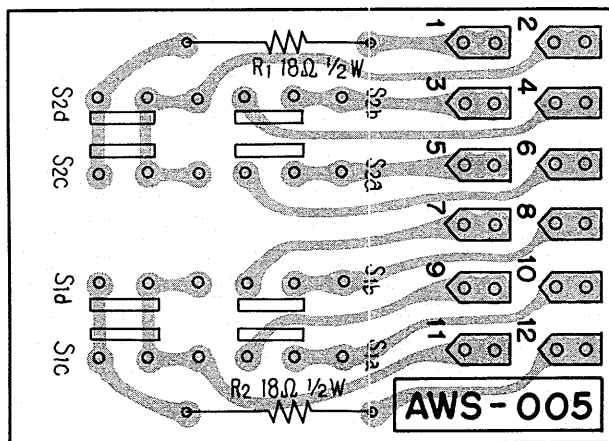
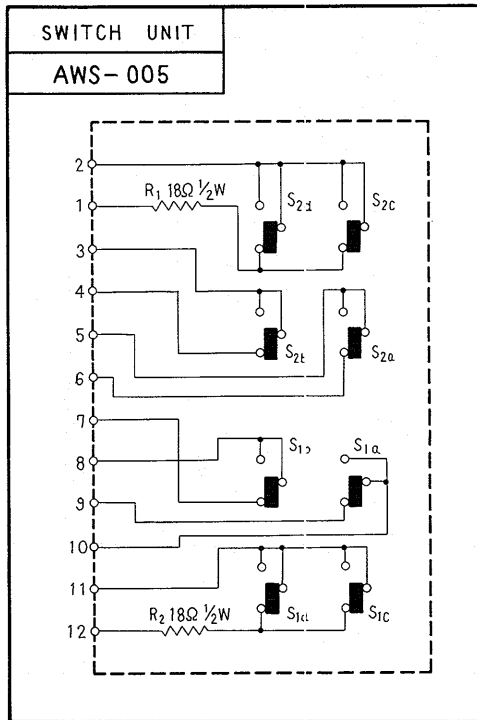

SWITCH UNIT (AWS-006)

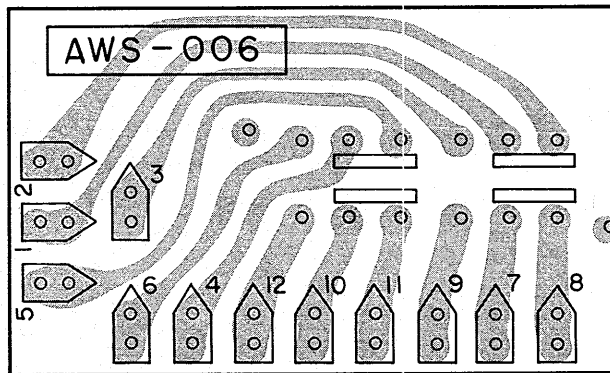
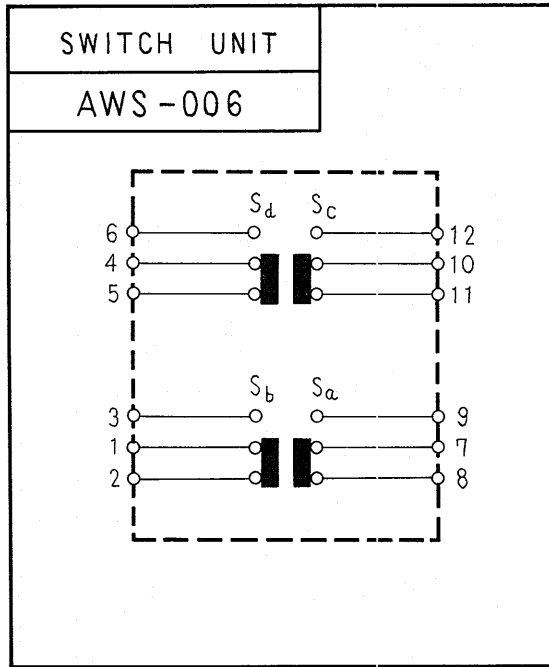

VR UNIT (AWX-002)

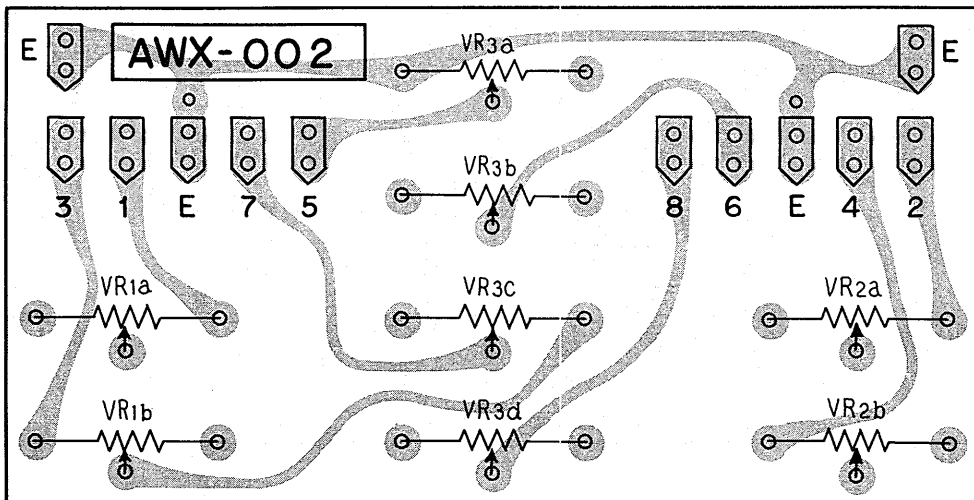
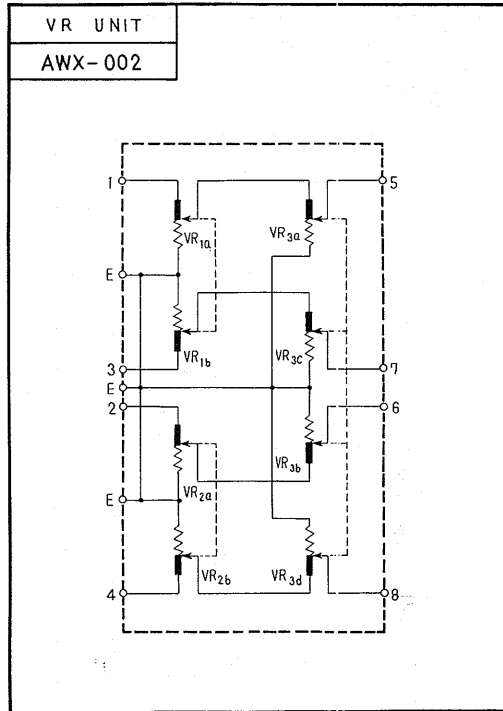

CR UNIT (AWX-003)

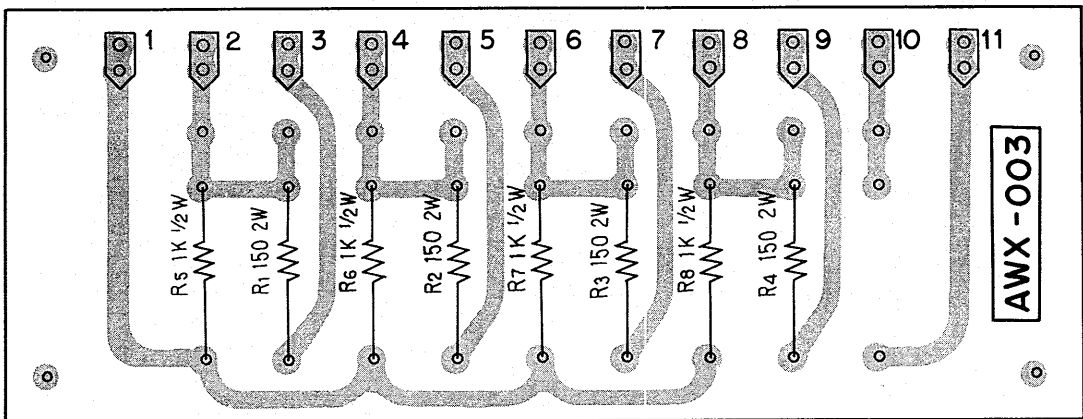
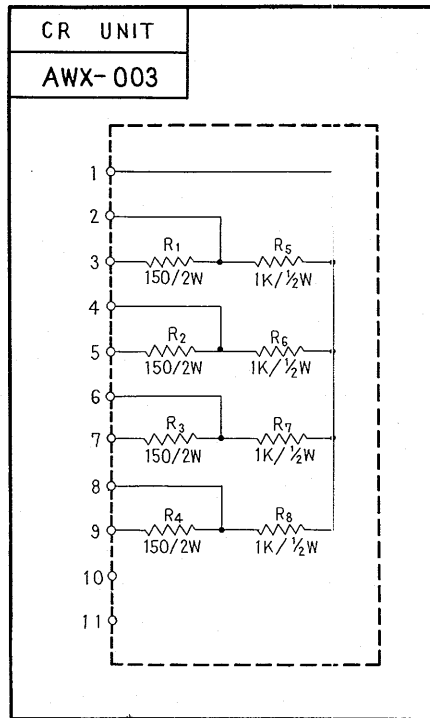

CR UNIT (AWX-004)

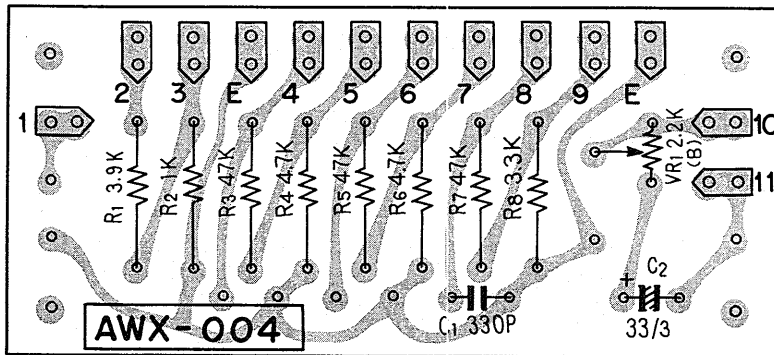
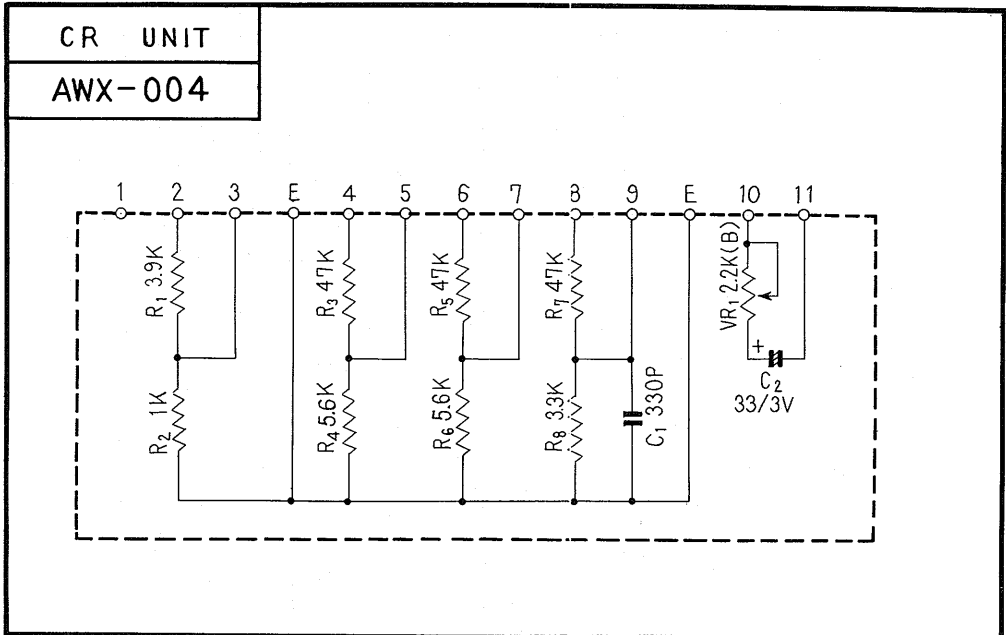

MISCELLANEOUS PARTS

CAPACITORS

IN μ F UNLESS OTHERWISE NOTED, p: μ F.

Symbol	Description	Part No.	
C1	Electrolytic 2200 35V	C52-077-0	
C2	Electrolytic 2200 35V	C52-077-0	
C3	Electrolytic 2200 35V	C52-077-0	
C4	Electrolytic 2200 35V	C52-077-0	
C5	Ceramic 0.01 DC 1.4kV	C43-003-0	
C6	Ceramic 0.01 DC 1.4kV	C43-003-0	
C7	Ceramic 0.01 DC 1.4kV	C43-003-0	
C8	Ceramic 0.01 DC 1.4kV	C43-003-0	
C9	Ceramic 0.01 50V	CKDYF 103Z 50	
C10	Ceramic 0.01 50V	CKDYF 103Z 50	
C11	Mylar 3300p 50V	CQMA 332J 50	
C12	Mylar 3300p 50V	CQMA 332J 50	
C13	Electrolytic 4700 63V	ACH-007-0	
C14	Ceramic 0.01 DC 1.4kV	C43-003-0	
C15	Ceramic 0.01 DC 1.4kV	C43-003-0	
C16	Ceramic 0.01 DC 1.4kV	C43-003-0	
C17	Electrolytic 220 6V	CEA 221P 6	
C18	Mylar 0.047 50V	CQMA 473K 50	

RESISTORS

IN Ω UNLESS OTHERWISE NOTED,k: k Ω , M: M Ω .

Symbol	Description	Part No.	
R1	Carbon film 4.7k	RD $\frac{1}{2}$ PS 472 K	
R2	Carbon film 4.7k	RD $\frac{1}{2}$ PS 472 K	
R3	Carbon film 4.7k	RD $\frac{1}{2}$ PS 472 K	
R4	Carbon film 4.7k	RD $\frac{1}{2}$ PS 472 K	
R9	Carbon film 39 $\frac{1}{2}$ W	RD $\frac{1}{2}$ PS 390 K	

POTENTIOMETER

Symbol	Description	Part No.	
VR1	4-gang. VOLUME	ACV-303-0	

COILS AND TRANSFORMER

Symbol	Description	Part No.	
L1	Choke Coil	T24-030-0	
L2	Ferrite Loopstick Antenna	T42-022-C	
T1	Power Transformer	ATT-010-B	

SWITCHES

Symbol	Description	Part No.	
S1	SELECTOR Switch	ASB-003-A	
S2	MODE Switch	ASC-008-A	
S3	PRE & MAIN Switch	S41-025-0	
S4	POWER Switch	ASG-003-0	

OTHERS

Symbol	Description	Part No.	
	Head Amp Unit	AWF-003-0	
	Q Unit	AWM-001-A	
	Control Amp Unit	AWG-003-0	
	Main Amp Unit	W23-007-0	
	Tuner Unit	AWE-003-C	
	Power Supply Unit	AWR-004-0	
	Switch Unit	AWS-004-B	
	Switch Unit	AWS-005-0	
	Switch Unit	AWS-006-0	
	VR Unit	AWX-002-0	
	CR Unit	AWX-003-0	
	CR Unit	AWX-004-B	
	Front Panel Ass'y	ANB-051-A	
	Wooden Case	AMM-004-D	
	Knob for TUNING	AAA-001-B	
	Knob for BASS, TREBLE and BALANCE	AAB-001-0	
	Knob for VOLUME, MODE and SELECTOR	AAB-003-A	
	Knob for POWER	AAD-001-0	
	Dial Pointer	AAF-002-B	
	Dial Glass	AAG-003-B	

Symbol	Description	Part No.	
	Signal Meter	AAW-001-A	
	Tuning Meter	AAW-002-A	
	Antenna Terminal	K11-043-C	
	4P Input Terminal Board	K22-010-E	
	16P Input Terminal Board	AKB-002-0	
	Pilot Lamp for Dial Glass	E22-017-0	
	Pilot Lamp for Program Indicator	E22-025-0	
	Pilot Lamp for Tuning and Signal Meters	E22-002-0	
	Fuse 2A	E21-035-A	
	Fuse 1.5A	E21-012-0	
	Fuse 3A	E21-022-0	
	Pilot Lamp Socket	K41-002-B	
	Headphones Jack	K72-026-0	
	Speaker Jack	K72-028-0	
	Spare AC Outlet	K82-014-0	
	Pilot Lamp (for Dial Glass) Socket	K91-005-A	
	Fuse Holder	K96-006-C	
	Line Voltage Selector	AKR-001-0	
	Lamp Ass'y	AEL-001-A	
	Dial Pulley	M42-041-C	
	Screw for Grounding	B11-012-A	
	AC Power Cord	D11-003-E	
	Operating Instructions	ARB-006-0	
	FM T-type Antenna	D52-013-0	
	AM Lead Antenna	D53-002-A	
	Dial Pulley Ass'y	AXA-003-A	
	AM Antenna Holder Ass'y	AXB-001-0	
	Packing Case	AHD-022-A	
	Tuning Shaft Ass'y	M42-071-F	
	4P Ground Terminal	K13-047-0	
	Short Pin Plug	K71-028-0	

Symbol	Description	Part No.	
	Washer (square)	M52-010-0	
	⊕ Machine Screw M4 x 30		
	Pin Plug	K72-015-A	
	Fuse 3A	E21-006-0	
	Speaker Plug	K72-007-B	
	Side Pad for packing	AHA-005-0	
	Paper Pad for Packing	AHB-001-0	
	Top Pad for Packing	AHB-002-A	
	Accessory Box	AHC-001-0	

TUNER UNIT (AWE-003)

CAPACITORS

Symbol	Description	Part No.	
C1	Ceramic 0.001 50V	CKDYF 102Z 50	
C2	Ceramic 15p 50V	CCDSL 150K 50	
C3	Ceramic 0.01 50V	CKDYF 103Z 50	
C4	Ceramic 0.01 50V	CKDYF 103Z 50	
C5	Ceramic 15p 50V	CCDSL 150K 50	
C6	Ceramic 1p 500V	CGB 010K 500	
C7	Ceramic 18p 50V	CCDSL 180K 50	
C8	Ceramic 12p 50V	CCDSL 120K 50	
C9	Ceramic 100p 50V	CCDSL 101K 50	
C10	Ceramic 0.01 50V	CKDYF 103Z 50	
C11	Ceramic 0.01 50V	CKDYF 103Z 50	
C12	Ceramic 1.5p 500V	CGB 1R5K 500	
C13	Ceramic 0.01 50V	CKDYF 103Z 50	
C14	Ceramic 0.01 50V	CKDYF 103Z 50	
C15	Ceramic 47p 50V	CCDSL 470K 50	

Symbol	Description	Part No.	
C16	Ceramic 6p 50V	CCDUJ 060D 50	
C17	Ceramic 0.01 50V	CKDYF 103Z 50	
C20	Ceramic 0.01 50V	CKDYF 103Z 50	
C21	Ceramic 0.01 50V	CKDYF 103Z 50	
C22	Ceramic 0.01 50V	CKDYF 103Z 50	
C23	Ceramic 18p 50V	CCDTJ 180K 50	
C24	Ceramic 0.01 50V	CKDYF 103Z 50	
C25	Ceramic 0.01 50V	CKDYF 103Z 50	
C26	Ceramic 2p 50V	CCDSL 020C 50	
C27	Ceramic 0.04 50V	CKDYF 403Z 50	
C28	Ceramic 5p 50V	CCDSL 050D 50	
C29	Ceramic 0.04 50V	CKDYF 403Z 50	
C30	Ceramic 0.01 50V	CKDYF 103Z 50	
C31	Ceramic 1p 500V	CGB 010K 500	
C32	Ceramic 0.04 50V	CKDYF 403Z 50	
C33	Ceramic 10p 50V	CCDSL 100F 50	
C34	Ceramic 0.01 50V	CKDYF 103Z 50	
C39	Ceramic 330p 50V	CKDYB 331K 50	
C40	Ceramic 330p 50V	CKDYB 331K 50	
C41	Electrolytic 4.7 25V	CEA 4R7P 25	
C42	Ceramic 250p 50V	CCDSL 251K 50	
C44	Ceramic 560p 50V	CKDYB 561K 50	
C45	Ceramic 330p 50V	CKDYB 331K 50	
C47	Ceramic 330p 50V	CKDYB 331K 50	
C48	Ceramic 0.04 50V	CKDYF 403Z 50	
C49	Ceramic 0.04 50V	CKDYF 403Z 50	
C50	Mylar 0.01 50V	CQMA 103K 50	
C51	Ceramic 15p 50V	CCDUJ 150K 50	
C52	Styrol 390p 50V	CQSA 391K 50	
C53	Mylar 0.01 50V	CQMA 103K 50	

Symbol	Description			Part No.
C54	Ceramic	0.04	50V	CKDYF 403Z 50
C55	Ceramic	0.04	50V	CKDYF 403Z 50
C56	Ceramic	0.04	50V	CKDYF 403Z 50
C57	Ceramic	0.04	50V	CKDYF 403Z 50
C58	Ceramic	0.04	50V	CKDYF 403Z 50
C60	Ceramic	0.04	50V	CKDYF 403Z 50
C61	Ceramic	0.04	50V	CKDYF 403Z 50
C62	Electrolytic	4.7	25V	CEA 4R7P 25
C63	Ceramic	0.04	50V	CKDYF 403Z 50
C64	Ceramic	0.01	50V	CKDYF 103Z 50
C65	Mylar	0.0047	50V	CQMA 472K 50
C66	Electrolytic	1	50V	CEA 010P 50
C67	Mylar	0.0027	50V	CQMA 272K 50
C69	Styrol	680p	50V	CQSA 681J 50
C70	Styrol	680p	50V	CQSA 681J 50
C71	Styrol	680p	50V	CQSA 681J 50
C72	Electrolytic	0.47	50V	CEA R47P 50
C73	Electrolytic	100	16V	CEA 101P 16
C75	Styrol	0.0033	50V	C15-011-0
C77	Styrol	0.0047	50V	C15-013-0
C78	Electrolytic	100	16V	CEA 101P 16
C79	Electrolytic	33	16V	CEA 330P 16
C80	Ceramic	330p	50V	CKDYB 331K 50
C81	Styrol	0.0047	50V	C15-013-0
C82	Electrolytic	0.47	50V	CEA R47P 50
C84	Mylar	0.0022	50V	CQMA 222K 50
C85	Mylar	0.0022	50V	CQMA 222K 50
C86	Styrol	300p	50V	CQSA 301J 50
C87	Styrol	300p	50V	CQSA 301J 50
C88	Electrolytic	0.47	50V	CEA R47P 50
C89	Electrolytic	0.47	50V	CEA R47P 50
C90	Mylar	0.0056	50V	CQMA 562K 50
C91	Mylar	0.0056	50V	CQMA 562K 50

RESISTORS

Symbol	Description		Part No.
R1	Carbon film	100	RD¼VS 101K
R2	Carbon film	100k	RD¼PS 104K
R3	Carbon film	100	RD¼VS 101K
R4	Carbon film	15k	RD¼VS 153K
R5	Carbon film	3.9k	RD¼VS 392K
R6	Carbon film	1k	RD¼VS 102K
R7	Carbon film	22	RD¼VS 220K
R8	Carbon film	2.2k	RD¼VS 222K
R9	Carbon film	12k	RD¼VS 123K
R10	Carbon film	8.2k	RD¼VS 822K
R11	Carbon film	150	RD¼VS 151K
R13	Carbon film	680	RD¼PS 681K
R14	Carbon film	470k	RD¼VS 474K
R15	Carbon film	68	RD¼PS 680K
R16	Carbon film	2.2k	RD¼VS 222K
R17	Carbon film	4.7k	RD¼VS 472K
R18	Carbon film	68	RD¼VS 680K
R19	Carbon film	1k	RD¼PS 102K
R20	Carbon film	220	RD¼PS 221K
R21	Carbon film	47k	RD¼PS 473K
R22	Carbon film	100	RD¼PS 101K
R23	Carbon film	330	RD¼PS 331K
R24	Carbon film	1k	RD¼PS 102K
R25	Carbon film	150	RD¼PS 151K
R27	Carbon film	22k	RD¼PS 223K

Symbol	Description	Part No.
R28	Carbon film 15k	RD¼PS 153K
R29	Carbon film 1k	RD¼PS 102K
R30	Carbon film 2.7k	RD¼PS 272K
R31	Carbon film 8.2k	RD¼PS 822K
R32	Carbon film 6.8k	RD¼PS 682K
R33	Carbon film 100	RD¼PS 101K
R34	Carbon film 39K	RD¼PS 393K
R35	Carbon film 100	RD¼PS 101K
R36	Carbon film 10k	RD¼PS 103K
R37	Carbon film 33k	RD¼PS 333K
R38	Carbon film 8.2k	RD¼PS 822K
R39	Carbon film 3.3k	RD¼PS 332K
R40	Carbon film 3.9k	RD¼PS 392K
R41	Carbon film 1k	RD¼PS 102K
R42	Carbon film 220k	RD¼PS 224K
R43	Carbon film 4.7k	RD¼PS 472K
R44	Carbon film 820	RD¼PS 821K
R45	Carbon film 18	RD¼PS 180K
R47	Carbon film 8.2k	RD¼PS 822K
R48	Carbon film 4.7k	RD¼PS 472K
R49	Carbon film 2.2k	RD¼PS 222K
R50	Carbon film 100k	RD¼PS 104K
R55	Carbon film 33k	RD¼PS 333K
R56	Carbon film 1.5k	RD¼PS 152K
R57	Carbon film 15k	RD¼PS 153K

Symbol	Description	Part No.
R59	Carbon film 150k	RD¼PS 154K
R62	Carbon film 47	RD¼PS 470K
R63	Carbon film 47k	RD¼PS 473K
R64	Carbon film 150k	RD¼PS 154K
R65	Carbon film 15k	RD¼PS 153K
R66	Carbon film 1k	RD¼PS 102K
R67	Carbon film 22	RD¼PS 220K
R70	Carbon film 1k	RD¼PS 102K
R71	Carbon film 100	RD¼PS 101K
R72	Carbon film 68k	RD¼PS 683K
R73	Carbon film 68k	RD¼PS 683K
R74	Carbon film 68k	RD¼PS 683K
R75	Carbon film 68k	RD¼PS 683K
R76	Carbon film 6.8k	RD¼PS 682K
R77	Carbon film 6.8k	RD¼PS 682K
R78	Carbon film 6.8k	RD¼PS 682K
R79	Carbon film 6.8k	RD¼PS 682K
R80	Carbon film 4.7k	RD¼PS 472K
R81	Carbon film 4.7k	RD¼PS 472K
R82	Carbon film 100	RD¼PS 101K
R86	Carbon film 1k	RD¼PS 102K
R87	Carbon film 1k	RD¼PS 102K

TRANSFORMERS AND COILS

Symbol	Description	Part No.	
T1	FM Antenna Coil	ATC-002-0	
T2	FM RF Coil	ATC-004-0	
T3	FM OSC Coil	ATC-003-0	
T4	Matching Transformer	ATE-001-A	
T5	FM IF Transformer	T73-035-A	
T6	FM IF Transformer	T73-036-0	
T7	FM IF Transformer	T74-003-A	
T8	AM OSC Coil	ATB-001-A	
T9	AM IF Transformer	T71-028-0	
T10	AM IF Transformer	T71-026-0	
T11	AM IF Transformer	T72-022-0	
T12	SCA Coil	T75-027-0	
T13	19kHz Transformer	T75-023-B	
T14	19kHz Transformer	T75-024-B	
T15	38kHz Transformer	T75-025-B	
T16	38kHz Filter Coil	T75-028-0	
T17	38kHz Filter Coil	T75-028-0	
T18	SCA Coil	T75-029-0	
L1	RF Choke Coil	T24-028-0	
L2	RF Choke Coil	T24-028-0	
L3	RF Choke Coil	T24-028-0	

SEMICONDUCTORS

Symbol	Description	Part No.	
Q1	2SK19-Y FET		
Q2	2SC763-D or C Transistor		
Q3	2SC763-D or C Transistor		
Q4	SE3001 Transistor		
Q5	SE3001 Transistor		
Q6	TA7060P-W IC		
Q7	SE3001 Transistor		
Q8	2SC710-D or DR Transistor		
Q9	2SC711-F Transistor		
Q10	2SC711-E or F Transistor		
Q11	2SC711-E or F Transistor		
Q12	2SC373 Transistor		
Q13	IC Filter	W53-046-0	
D2	1S188 FM-1 Diode		
D3	1S188 FM-1 Diode		
D4	1S188 FM-1 Diode		
D5	1S188 FM-1 Diode		
D6	1S188 FM-1 Diode		
D7	1S188 FM-1 Diode		
D8	1S188 FM-1 Diode		
D9	1S188 FM-1 Diode		
D10	1S188 FM-1 Diode		
D11	1S188 FM-1 Diode		
D12	1S188 FM-1 Diode		
D13	1S188 FM-1 Diode		
D14	1S188 FM-1 Diode		
D15	1S188 FM-1 Diode		
D16	1S188 FM-1 Diode		
D17	1S188 FM-1 Diode		

Q UNIT (AWM-001)

CAPACITORS

Symbol	Description			Part No.
C1	Electrolytic	0.33	25V	CSSA R33X 25
C2	Electrolytic	0.33	25V	CSSA R33X 25
C3	Electrolytic	0.33	25V	CSSA R33X 25
C4	Electrolytic	100	35V	CEA 101P 35
C5	Mylar	0.1	50V	CQMA 104K 50
C6	Mylar	0.1	50V	CQMA 104K 50
C7	Electrolytic	3.3	10V	CSSA 3R3X 10
C8	Electrolytic	3.3	10V	CSSA 3R3X 10
C9	Electrolytic	0.33	25V	CSSA R33X 25
C10	Electrolytic	0.33	25V	CSSA R33X 25
C11	Electrolytic	22	6V	CEA 220P 6
C12	Electrolytic	22	6V	CEA 220P 6
C13	Electrolytic	0.33	25V	CSSA R33X 25
C14	Electrolytic	0.33	25V	CSSA R33X 25
C15	Electrolytic	3.3	25V	CEA 3R3P 25
C16	Electrolytic	3.3	25V	CEA 3R3P 25
C17	Ceramic	12p	50V	CCDSL 120K 50
C18	Ceramic	12p	50V	CCDSL 120K 50
C19	Electrolytic	0.33	25V	CSSA R33X 25
C20	Electrolytic	0.33	25V	CSSA R33X 25
C21	Mylar	0.022	50V	CQMA 223J 50
C22	Mylar	0.1	50V	CQMA 104J 50
C23	Mylar	0.0022	50V	CQMA 222J 50
C24	Mylar	0.0082	50V	CQMA 822J 50
C25	Styrol	220p	50V	CQSA 221J 50
C26	Mylar	0.0012	50V	CQMA 122J 50
C27	Mylar	0.1	50V	CQMA 104K 50
C28	Mylar	0.1	50V	CQMA 104K 50

RESISTORS

Symbol	Description		Part No.
R1	Carbon film	56k	RD¼PS 563J
R2	Carbon film	56k	RD¼PS 563J
R3	Carbon film	56k	RD¼PS 563J
R4	Carbon film	56k	RD¼PS 563J
R5	Carbon film	180k	RD¼PS 184K
R6	Carbon film	180k	RD¼PS 184K
R7	Carbon film	120k	RD¼PS 124K
R8	Carbon film	120k	RD¼PS 124K
R9	Carbon film	2.7k	RD¼PS 272J
R10	Carbon film	2.7k	RD¼PS 272J
R11	Carbon film	5.6k	RD¼PS 562J
R12	Carbon film	5.6k	RD¼PS 562J
R13	Carbon film	62k	RD¼PS 623J
R14	Carbon film	120k	RD¼PS 124J
R15	Carbon film	120k	RD¼PS 124J
R16	Carbon film	62k	RD¼PS 623J
R17	Carbon film	56k	RD¼PS 563J
R18	Carbon film	62k	RD¼PS 623J
R19	Carbon film	62k	RD¼PS 623J
R20	Carbon film	56k	RD¼PS 563J
R21	Carbon film	120k	RD¼PS 124J
R22	Carbon film	62k	RD¼PS 623J
R23	Carbon film	180k	RD¼PS 184J
R24	Carbon film	180k	RD¼PS 184J
R25	Carbon film	150k	RD¼PS 154J

Symbol	Description	Part No.
R26	Carbon film 150k	RD¼PS 154J
R27	Carbon film 39k	RD¼PS 393K
R28	Carbon film 39k	RD¼PS 393K
R29	Carbon film 5.6k	RD¼PS 562K
R30	Carbon film 5.6k	RD¼PS 562K
R31	Carbon film 820	RD¼PS 821K
R32	Carbon film 820	RD¼PS 821K
R33	Carbon film 120k	RD¼PS 124K
R34	Carbon film 120k	RD¼PS 124K
R35	Carbon film 56k	RD¼PS 563K
R36	Carbon film 56k	RD¼PS 563K
R37	Carbon film 150k	RD¼PS 154K
R38	Carbon film 150k	RD¼PS 154K
R39	Carbon film 22k	RD¼PS 223K
R40	Carbon film 22k	RD¼PS 223K
R41	Carbon film 5.6k	RD¼PS 562J
R42	Carbon film 5.6k	RD¼PS 562J
R43	Carbon film 1k	RD¼PS 102J
R44	Carbon film 1k	RD¼PS 102J
R45	Carbon film 120k	RD¼PS 124K
R46	Carbon film 120k	RD¼PS 124K
R47	Carbon film 8.2k	RD¼PS 822K
R48	Carbon film 8.2k	RD¼PS 822K
R49	Carbon film 8.2k	RD¼PS 822K
R50	Carbon film 8.2k	RD¼PS 822K
R51	Carbon film 82k	RD¼PS 823K
R52	Carbon film 82k	RD¼PS 823K
R53	Carbon film 5.6k	RD¼PS 562K
R54	Carbon film 5.6k	RD¼PS 562K
R55	Carbon film 5.6k	RD¼PS 562K

Symbol	Description	Part No.
R56	Carbon film 5.6k	RD¼PS 562K
R57	Carbon film 56k	RD¼PS 563K
R58	Carbon film 56k	RD¼PS 563K
R59	Carbon film 2.7k	RD¼PS 272K
R60	Carbon film 2.7k	RD¼PS 272K
R61	Carbon film 2.7k	RD¼PS 272K
R62	Carbon film 2.7k	RD¼PS 272K
R63	Carbon film 120k	RD¼PS 124K
R64	Carbon film 120k	RD¼PS 124K
R65	Carbon film 27k	RD¼PS 273K
R66	Carbon film 27k	RD¼PS 273K
R67	Carbon film 470k	RD¼PS 474J

SEMICONDUCTORS

Symbol	Description	Part No.
Q1	2SC870-F or G Transistor	
Q2	2SC870-F or G Transistor	
Q3	2SC870-F or G Transistor	
Q4	2SC870-F or G Transistor	
Q5	2SC870-F or G Transistor	
Q6	2SC870-F or G Transistor	
Q7	2SC870-F or G Transistor	
Q8	2SC870-F or G Transistor	
Q9	2SC870-F or G Transistor	
Q10	2SC870-F or G Transistor	
Q11	2SC870-F or G Transistor	
Q12	2SC870-F or G Transistor	

CONTROL AMP UNIT (AWG-003)

CAPACITORS

Symbol	Description			Part No.
C1	Electrolytic	0.47	25V	CSSA R47M 25
C2	Electrolytic	0.47	25V	CSSA R47M 25
C3	Electrolytic	0.47	25V	CSSA R47M 25
C4	Electrolytic	0.47	25V	CSSA R47M 25
C5	Electrolytic	10	25V	CEA 100P 25
C6	Electrolytic	10	25V	CEA 100P 25
C7	Electrolytic	10	25V	CEA 100P 25
C8	Electrolytic	10	25V	CEA 100P 25
C9	Ceramic	47p	50V	CCDSL 470K 50
C10	Ceramic	47p	50V	CCDSL 470K 50
C11	Ceramic	47p	50V	CCDSL 470K 50
C12	Ceramic	47p	50V	CCDSL 470K 50
C13	Electrolytic	1	25V	CSSA 010M 25
C14	Electrolytic	1	25V	CSSA 010M 25
C15	Electrolytic	1	25V	CSSA 010M 25
C16	Electrolytic	1	25V	CSSA 010M 25
C17	Mylar	0.039	50V	CQMA 393K 50
C18	Mylar	0.039	50V	CQMA 393K 50
C19	Mylar	0.039	50V	CQMA 393K 50
C20	Mylar	0.039	50V	CQMA 393K 50
C21	Mylar	0.039	50V	CQMA 393K 50
C22	Mylar	0.039	50V	CQMA 393K 50
C23	Mylar	0.039	50V	CQMA 393K 50
C24	Mylar	0.039	50V	CQMA 393K 50
C25	Electrolytic	10	25V	CEA 100P 25

Symbol	Description			Part No.
C26	Electrolytic	10	25V	CEA 100P 25
C27	Electrolytic	10	25V	CEA 100P 25
C28	Electrolytic	10	25V	CEA 100P 25
C29	Mylar	0.0018	50V	CQMA 182K 50
C30	Mylar	0.0018	50V	CQMA 182K 50
C31	Mylar	0.0018	50V	CQMA 182K 50
C32	Mylar	0.0018	50V	CQMA 182K 50
C33	Electrolytic	47	16V	CEA 470P 16
C34	Electrolytic	47	16V	CEA 470P 16
C35	Electrolytic	47	16V	CEA 470P 16
C36	Electrolytic	47	16V	CEA 470P 16
C37	Electrolytic	1	25V	CSSA 010M 25
C38	Electrolytic	1	25V	CSSA 010M 25
C39	Electrolytic	1	25V	CSSA 010M 25
C40	Electrolytic	1	25V	CSSA 010M 25
C41	Ceramic	150p	50V	CCDSL 151K 50
C42	Ceramic	150p	50V	CCDSL 151K 50
C43	Ceramic	150p	50V	CCDSL 151K 50
C44	Ceramic	150p	50V	CCDSL 151K 50
C45	Electrolytic	100	25V	CEA 101P 25
C46	Electrolytic	100	25V	CEA 101P 25
C47	Electrolytic	100	25V	CEA 101P 25
C48	Electrolytic	100	25V	CEA 101P 25

RESISTORS

Symbol	Description	Part No.
R1	Carbon film 1k	RD¼PS 102K
R2	Carbon film 1k	RD¼PS 102K
R3	Carbon film 1k	RD¼PS 102K
R4	Carbon film 1k	RD¼PS 102K
R5	Carbon film 68k	RD¼PS 683K
R6	Carbon film 68k	RD¼PS 683K
R7	Carbon film 68k	RD¼PS 683K
R8	Carbon film 68k	RD¼PS 683K
R9	Carbon film 33k	RD¼PS 333K
R10	Carbon film 33k	RD¼PS 333K
R11	Carbon film 33k	RD¼PS 333K
R12	Carbon film 33k	RD¼PS 333K
R13	Carbon film 47k	RD¼PS 473K
R14	Carbon film 47k	RD¼PS 473K
R15	Carbon film 47k	RD¼PS 473K
R16	Carbon film 47k	RD¼PS 473K
R17	Carbon film 12k	RD¼PS 123K
R18	Carbon film 12k	RD¼PS 123K
R19	Carbon film 12k	RD¼PS 123K
R20	Carbon film 12k	RD¼PS 123K
R21	Carbon film 8.2k	RD¼PS 822K
R22	Carbon film 8.2k	RD¼PS 822K
R23	Carbon film 8.2k	RD¼PS 822K
R24	Carbon film 8.2k	RD¼PS 822K
R25	Carbon film 5.6k	RD¼PS 562K
R26	Carbon film 5.6k	RD¼PS 562K
R27	Carbon film 5.6k	RD¼PS 562K
R28	Carbon film 5.6k	RD¼PS 562K
R29	Carbon film 33	RD¼PS 330K
R30	Carbon film 33	RD¼PS 330K

Symbol	Description	Part No.
R31	Carbon film 33	RD¼PS 330K
R32	Carbon film 33	RD¼PS 330K
R33	Carbon film 10k	RD¼PS 103K
R34	Carbon film 10k	RD¼PS 103K
R35	Carbon film 10k	RD¼PS 103K
R36	Carbon film 10k	RD¼PS 103K
R37	Carbon film 10k	RD¼PS 103K
R38	Carbon film 10k	RD¼PS 103K
R39	Carbon film 10k	RD¼PS 103K
R40	Carbon film 10k	RD¼PS 103K
R41	Carbon film 10k	RD¼PS 103K
R42	Carbon film 10k	RD¼PS 103K
R43	Carbon film 10k	RD¼PS 103K
R44	Carbon film 10k	RD¼PS 103K
R45	Carbon film 4.7k	RD¼PS 472K
R46	Carbon film 4.7k	RD¼PS 472K
R47	Carbon film 4.7k	RD¼PS 472K
R48	Carbon film 4.7k	RD¼PS 472K
R49	Carbon film 4.7k	RD¼PS 472K
R50	Carbon film 4.7k	RD¼PS 472K
R51	Carbon film 4.7k	RD¼PS 472K
R52	Carbon film 4.7k	RD¼PS 472K
R53	Carbon film 330k	RD¼PS 334K
R54	Carbon film 330k	RD¼PS 334K
R55	Carbon film 330k	RD¼PS 334K
R56	Carbon film 330k	RD¼PS 334K
R57	Carbon film 220k	RD¼PS 224K
R58	Carbon film 220k	RD¼PS 224K
R59	Carbon film 220k	RD¼PS 224K
R60	Carbon film 220k	RD¼PS 224K

Symbol	Description	Part No.	
R61	Carbon film 10k	RD¼PS 103K	
R62	Carbon film 10k	RD¼PS 103K	
R63	Carbon film 10k	RD¼PS 103K	
R64	Carbon film 10k	RD¼PS 103K	
R65	Carbon film 2.2k	RD¼PS 222K	
R66	Carbon film 2.2k	RD¼PS 222K	
R67	Carbon film 2.2k	RD¼PS 222K	
R68	Carbon film 2.2k	RD¼PS 222K	
R69	Carbon film 3.3k	RD¼PS 332K	
R70	Carbon film 3.3k	RD¼PS 332K	
R71	Carbon film 3.3k	RD¼PS 332K	
R72	Carbon film 3.3k	RD¼PS 332K	
R73	Carbon film 270	RD¼PS 271K	
R74	Carbon film 270	RD¼PS 271K	
R75	Carbon film 270	RD¼PS 271K	
R76	Carbon film 270	RD¼PS 271K	
R77	Carbon film 560k	RD¼PS 564K	
R78	Carbon film 560k	RD¼PS 564K	
R79	Carbon film 560k	RD¼PS 564K	
R80	Carbon film 560k	RD¼PS 564K	

POTENTIOMETERS

Symbol	Description	Part No.	
VR1	100k B, dual	C82-045-0	
VR2	100k B, dual	C82-045-0	
VR3	100k B, dual	C82-045-0	
VR4	100k B, dual	C82-045-0	

SEMICONDUCTORS

Symbol	Description	Part No.	
Q1	2SC871-E or F Transistor		
Q2	2SC871-E or F Transistor		
Q3	2SC871-E or F Transistor		
Q4	2SC871-E or F Transistor		
Q5	2SA572-4 or 5 Transistor		
Q6	2SA572-4 or 5 Transistor		
Q7	2SA572-4 or 5 Transistor		
Q8	2SA572-4 or 5 Transistor		
Q9	2SC871-E or F Transistor		
Q10	2SC871-E or F Transistor		
Q11	2SC871-E or F Transistor		
Q12	2SC871-E or F Transistor		

HEAD AMP UNIT (AWF-003)

CAPACITORS

Symbol	Description			Part No.
C1	Electrolytic	3.3	16V	CSSA 3R3M 16
C2	Electrolytic	3.3	16V	CSSA 3R3M 16
C3	Ceramic	30p	50V	CCDSL 300K 50
C4	Ceramic	30p	50V	CCDSL 300K 50
C5	Ceramic	100p	50V	CCDSL 101K 50
C6	Ceramic	100p	50V	CCDSL 101K 50
C7	Electrolytic	0.47	25V	CSSA R47M 25
C8	Electrolytic	0.47	25V	CSSA R47M 25
C9	Electrolytic	3.3	25V	CEA 3R3P 25
C10	Electrolytic	3.3	25V	CEA 3R3P 25
C11	Mylar	0.01	50V	CQMA 103K 50
C12	Mylar	0.01	50V	CQMA 103K 50
C13	Mylar	0.0033	50V	CQMA 332K 50
C14	Mylar	0.0033	50V	CQMA 332K 50
C15	Electrolytic	100	35V	CEA 101P 35
C16	Electrolytic	100	35V	CEA 101P 35
C17	Ceramic	100p	50V	CCDSL 101K 50
C18	Ceramic	100p	50V	CCDSL 101K 50
C19	Ceramic	100p	50V	CCDSL 101K 50
C20	Ceramic	100p	50V	CCDSL 101K 50

RESISTORS

Symbol	Description		Part No.
R1	Carbon film	1k	RD¼PS 102K
R2	Carbon film	1k	RD¼PS 102K
R3	Carbon film	68k	RD¼PS 683K
R4	Carbon film	68k	RD¼PS 683K
R5	Carbon film	180k	RD¼PS 184K
R6	Carbon film	180k	RD¼PS 184K
R7	Carbon film	120k	RD¼PS 124K
R8	Carbon film	120k	RD¼PS 124K
R9	Carbon film	390	RD¼PS 391K
R10	Carbon film	390	RD¼PS 391K
R11	Carbon film	560k	RD¼PS 564KNL
R12	Carbon film	560k	RD¼PS 564KNL
R13	Carbon film	10k	RD¼PS 103K
R14	Carbon film	10k	RD¼PS 103K
R15	Carbon film	2.7k	RD¼PS 272K
R16	Carbon film	2.7k	RD¼PS 272K
R17	Carbon film	330k	RD¼PS 334K
R18	Carbon film	330k	RD¼PS 334K
R19	Carbon film	27k	RD¼PS 273K
R20	Carbon film	27k	RD¼PS 273K
R21	Carbon film	56k	RD¼PS 563K
R22	Carbon film	56k	RD¼PS 563K
R23	Carbon film	2.2k	RD¼PS 222K
R24	Carbon film	2.2k	RD¼PS 222K
R25	Carbon film	12k	RD¼PS 123K
R26	Carbon film	12k	RD¼PS 123K

SEMICONDUCTORS

Symbol	Description	Part No.	
Q1	2SC870-E or F Transistor		
Q2	2SC870-E or F Transistor		
Q3	2SC871-E or F Transistor		
Q4	2SC871-E or F Transistor		

POWER SUPPLY UNIT (AWR-004)

CAPACITORS

Symbol	Description	Part No.	
C1	Electrolytic 100 50V	CEA 101P 50	
C2	Electrolytic 220 35V	CEA 221P 35	
C3	Electrolytic 220 35V	CEA 221P 35	
C4	Electrolytic 220 35V	CEA 221P 35	
C5	Electrolytic 220 35V	CEA 221P 35	
C6	Electrolytic 100 25V	CEA 101P 25	
C7	Electrolytic 100 25V	CEA 101P 25	
C8	Electrolytic 100 16V	CEA 101P 16	
C9	Ceramic 0.01 DC 1.4kV	C43-003-0	
C10	Ceramic 0.01 DC 1.4kV	C43-003-0	
C11	Ceramic 0.01 DC 1.4kV	C43-003-0	
C12	Ceramic 0.01 DC 1.4kV	C43-003-0	
C13	Ceramic 0.01 500V	CKDYB 103M 500	
C14	Ceramic 100p 50V	CCDSL 101K 50	

RESISTORS

Symbol	Description	Part No.	
R1	Carbon film 12k 1/2W	RD1/2PS 123K	
R2	Metal oxide 220 1W	RS1P 221K	
R3	Carbon film 8.2k 1/2W	RD1/2PS 822K	
R4	Carbon film 3.9k 1/2W	RD1/2PS 392K	
R5	Carbon film 33k 1/2W	RD1/2PS 333K	
R6	Carbon film 22k 1/2W	RD1/2PS 223K	
R7	Carbon film 330 1/2W	RD1/2PS 331K	
R8	Carbon film 2.2k 1/2W	RD1/2PS 222K	
R9	Carbon film 2.2k 1/2W	RD1/2PS 222K	
R10	Metal oxide 470 2W	RS2P 471K	
R11	Carbon film 47 1/2W	RD1/2PS 470K	
R12	Carbon film 10 1/2W	RD1/2PS 100K	

SEMICONDUCTORS

Symbol	Description	Part No.	
Q1	2SC1061 Transistor		
Q2	2SC968 or 2SC905 Transistor		
Q3	2SC971 Transistor		
D1	SR3AM-8 Diode		
D2	SR3AM-8 Diode		
D3	SR2AM-8 Diode		
D4	SR3AM-8 Diode		
D5	1S180 Diode		
D6	WZ-130 Zener Diode		

SWITCH UNIT (AWS-004)

CAPACITORS

Symbol	Description			Part No.
C1	Mylar	0.033	50V	CQMA 333K 50
C2	Mylar	0.033	50V	CQMA 333K 50
C3	Mylar	0.033	50V	CQMA 333K 50
C4	Mylar	0.033	50V	CQMA 333K 50
C5	Mylar	0.018	50V	CQMA 183K 50
C6	Mylar	0.018	50V	CQMA 183K 50
C7	Mylar	0.018	50V	CQMA 183K 50
C8	Mylar	0.018	50V	CQMA 183K 50
C9	Ceramic	100p	50V	CCDSL 101K 50
C10	Ceramic	100p	50V	CCDSL 101K 50
C11	Ceramic	100p	50V	CCDSL 101K 50
C12	Ceramic	100p	50V	CCDSL 101K 50
C13	Mylar	0.033	50V	CQMA 333K 50
C14	Mylar	0.033	50V	CQMA 333K 50
C15	Mylar	0.033	50V	CQMA 333K 50
C16	Mylar	0.033	50V	CQMA 333K 50

RESISTORS

Symbol	Description		Part No.
R1	Carbon film	150k	RD¼PS 154K
R2	Carbon film	150k	RD¼PS 154K
R3	Carbon film	150k	RD¼PS 154K
R4	Carbon film	150k	RD¼PS 154K
R5	Carbon film	470k	RD¼PS 474K
R6	Carbon film	470k	RD¼PS 474K
R7	Carbon film	470k	RD¼PS 474K
R8	Carbon film	470k	RD¼PS 474K
R9	Carbon film	12k	RD¼PS 123K
R10	Carbon film	12k	RD¼PS 123K
R11	Carbon film	12k	RD¼PS 123K
R12	Carbon film	12k	RD¼PS 123K
R13	Carbon film	10k	RD¼PS 103K
R14	Carbon film	10k	RD¼PS 103K
R15	Carbon film	10k	RD¼PS 103K
R16	Carbon film	10k	RD¼PS 103K
R17	Carbon film	10k	RD¼PS 103K
R18	Carbon film	10k	RD¼PS 103K
R19	Carbon film	10k	RD¼PS 103K
R20	Carbon film	10k	RD¼PS 103K

SWITCH

Symbol	Description	Part No.
	Mini Switch	ASG-005-0

SWITCH UNIT (AWS-005)

RESISTORS

Symbol	Description	Part No.	
R1	Carbon film 18 ½W	RD½PS 180K	
R2	Carbon film 18 ½W	RD½PS 180K	

SWITCH

Symbol	Description	Part No.	
	Mini switch	S31-028-0	

OTHER

Symbol	Description	Part No.	
	Knob for Mini switch	A19-077-0	

SWITCH UNIT (AWS-006)

SWITCH

Symbol	Description	Part No.	
	Mini switch	ASG-004-0	

OTHER

Symbol	Description	Part No.	
	Knob for Mini switch	A19-079-0	

VR UNIT (AWX-002)

POTENTIOMETERS

Symbol	Description	Part No.	
VR1	500k HB, dual	ACT-102-0	
VR2	500k HB, dual	ACT-102-0	
VR3	500k HB, 4-gang	ACT-301-A	

CR UNIT (AWX-003)

RESISTORS

Symbol	Description	Part No.	
R1	Metal oxide 150 2W	RS2P 151K	
R2	Metal oxide 150 2W	RS2P 151K	
R3	Metal oxide 150 2W	RS2P 151K	
R4	Metal oxide 150 2W	RS2P 151K	
R5	Carbon film 1k ½W	RD½PS 102K	
R6	Carbon film 1k ½W	RD½PS 102K	
R7	Carbon film 1k ½W	RD½PS 102K	
R8	Carbon film 1k ½W	RD½PS 102K	

CR UNIT (AWX-004)

CR UNIT (AWX-004)

CAPACITORS

Symbol	Description	Part No.	
C1	Ceramic 330p 50V	CKDYB 331K 50	
C2	Electrolytic 33 10V	CEA 330P 10	

RESISTORS

Symbol	Description	Part No.	
R1	Carbon film 3.9k	RD¼PS 392K	
R2	Carbon film 1k	RD¼PS 102K	
R3	Carbon film 47k	RD¼PS 473K	
R4	Carbon film 4.7k	RD¼PS 472K	
R5	Carbon film 47k	RD¼PS 473K	
R6	Carbon film 4.7k	RD¼PS 472K	
R7	Carbon film 47k	RD¼PS 473K	
R8	Carbon film 3.3k	RD¼PS 332K	

POTENTIOMETER

Symbol	Description	Part No.	
VR1	2.2k B, Semi-fixed	ACP-001-0	

MAIN AMP UNIT (W23-007)

CAPACITORS

Symbol	Description			Part No.
C1	Electrolytic	3.3	25V	CEA 3R3P 25
C2	Electrolytic	3.3	25V	CEA 3R3P 25
C3	Electrolytic	3.3	25V	CEA 3R3P 25
C4	Electrolytic	3.3	25V	CEA 3R3P 25
C5	Electrolytic	100	50V	CEA 101P 50
C6	Electrolytic	100	50V	CEA 101P 50
C7	Electrolytic	100	50V	CEA 101P 50
C8	Electrolytic	100	50V	CEA 101P 50
C9	Ceramic	50p	50V	CCDSL 500K 50
C10	Ceramic	50p	50V	CCDSL 500K 50
C11	Electrolytic	100	6V	CEA 101P 6
C12	Electrolytic	100	6V	CEA 101P 6
C13	Mylar	0.022	50V	CQMA 223M 50
C14	Mylar	0.022	50V	CQMA 223M 50
C15	Ceramic	100p	50V	CCDSL 101K 50
C16	Ceramic	100p	50V	CCDSL 101K 50

RESISTORS

Symbol	Description		Part No.
R1	Carbon film	2.2k	RD $\frac{1}{4}$ PS 222K
R2	Carbon film	2.2k	RD $\frac{1}{4}$ PS 222K
R3	Carbon film	2.2M	RD $\frac{1}{4}$ PS 225K
R4	Carbon film	2.2M	RD $\frac{1}{4}$ PS 225K
R5	Carbon film	82k	RD $\frac{1}{4}$ PS 823K
R6	Carbon film	82k	RD $\frac{1}{4}$ PS 823K
R7	Carbon film	10k	RD $\frac{1}{4}$ PS 103K
R8	Carbon film	10k	RD $\frac{1}{4}$ PS 103K
R9	Carbon film	15k	RD $\frac{1}{4}$ PS 153K
R10	Carbon film	15k	RD $\frac{1}{4}$ PS 153K
R11	Carbon film	150	RD $\frac{1}{4}$ PS 151K
R12	Carbon film	150	RD $\frac{1}{4}$ PS 151K
R13	Carbon film	820	RD $\frac{1}{4}$ PS 821K
R14	Carbon film	820	RD $\frac{1}{4}$ PS 821K
R15	Carbon film	39k	RD $\frac{1}{4}$ PS 393K
R16	Carbon film	39k	RD $\frac{1}{4}$ PS 393K
R17	Carbon film	3.3k	RD $\frac{1}{4}$ PS 332K
R18	Carbon film	3.3k	RD $\frac{1}{4}$ PS 332K
R19	Carbon film	4.7k	RD $\frac{1}{4}$ PS 472K
R20	Carbon film	4.7k	RD $\frac{1}{4}$ PS 472K
R21	Carbon film	150	RD $\frac{1}{4}$ PS 151K
R22	Carbon film	150	RD $\frac{1}{4}$ PS 151K
R23	Carbon film	560	RD $\frac{1}{4}$ PS 561K
R24	Carbon film	560	RD $\frac{1}{4}$ PS 561K
R25	Carbon film	22	RD $\frac{1}{4}$ PS 220K

SEMICONDUCTORS

Symbol	Description	Part No.
Q1	25C732 Transistor	
Q2	25C732 Transistor	
Q3	25C497-0 or Y Transistor	
Q4	25C497-0 or Y Transistor	
Q5	25C497-0 or Y Transistor	
Q6	25C497-0 or Y Transistor	
Q7	25A497-0 or Y Transistor	
Q8	25A497-0 or Y Transistor	
Q9	25C793-Y or BL Transistor	
Q10	25C793-Y or BL Transistor	
Q11	25C793-Y or BL Transistor	
Q12	25C793-Y or BL Transistor	
D1	SV-4A Varistor	
D2	SV-4A Varistor	
TH1	31D27 Thermistor	
TH2	31D27 Thermistor	

Symbol	Description	Part No.
R26	Carbon film 22 1/2W	RD1/2PS 220K
R27	Carbon film 150	RD1/2PS 151K
R28	Carbon film 150	RD1/2PS 151K
R29	Carbon film 22 1/2W	RD1/2PS 220K
R30	Carbon film 22 1/2W	RD1/2PS 220K
R31	Carbon film 150	RD1/2PS 151K
R32	Carbon film 150	RD1/2PS 151K
R33	Wire wound 0.5 2W	RT2P 0R5K
R34	Wire wound 0.5 2W	RT2P 0R5K
R35	Wire wound 0.5 2W	RT2P 0R5K
R36	Wire wound 0.5 2W	RT2P 0R5K
R37	Carbon film 27k	RD1/2PS 273K
R38	Carbon film 27k	RD1/2PS 273K
R39	Carbon film 10	RD1/2PS 100K
R40	Carbon film 10	RD1/2PS 100K
R41	Carbon film 8.2k	RD1/2PS 822K
R42	Carbon film 8.2k	RD1/2PS 822K

POTENTIOMETERS

Symbol	Description	Part No.
VR1	47k-B, Semi-fixed	C92-048-0
VR2	47k-B, Semi-fixed	C92-048-0
VR3	100-B, Semi-fixed	C92-063-0
VR4	100-B, Semi-fixed	C92-063-0

10 • PACKING METHOD AND PARTS

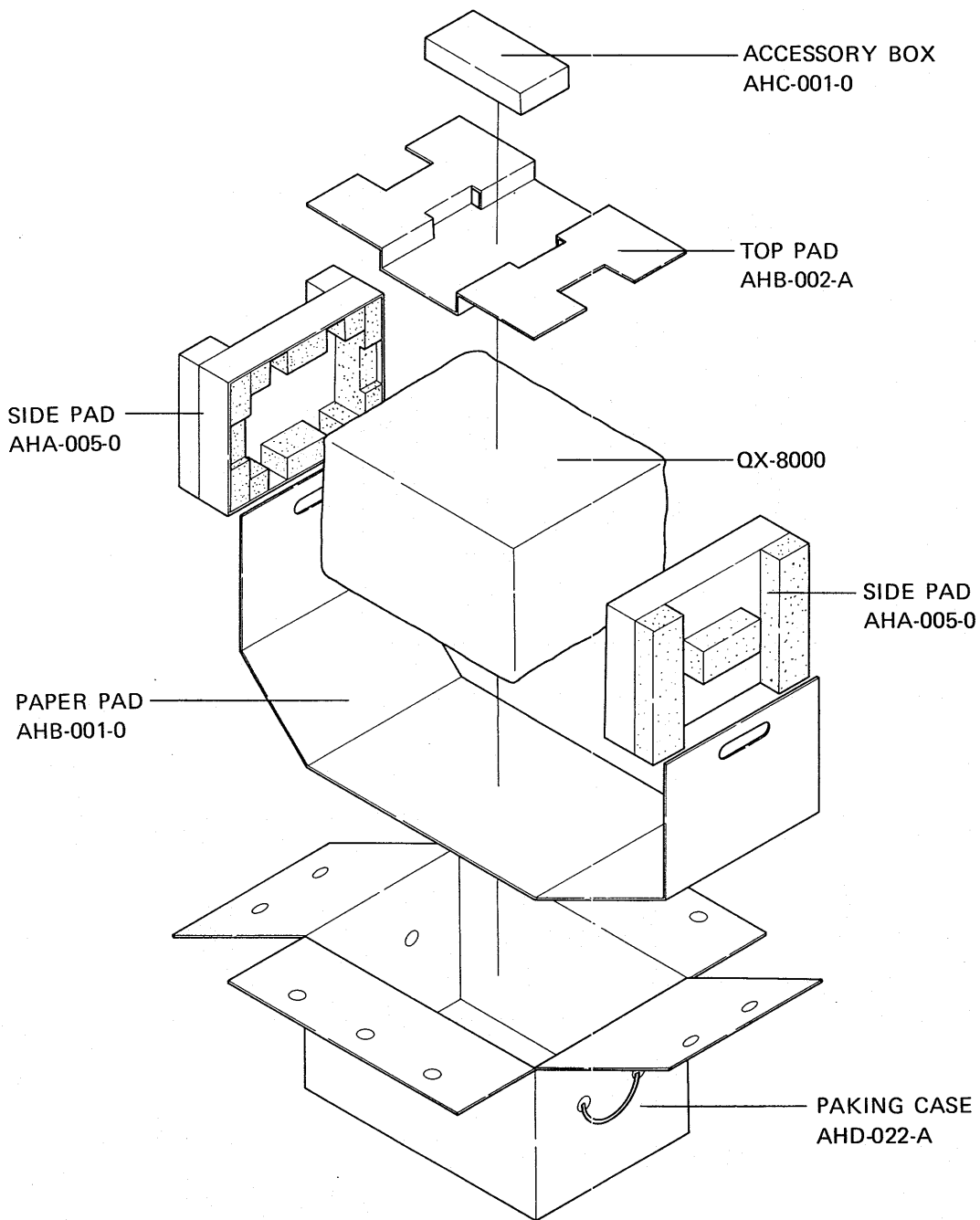

PIONEER ELECTRONIC CORPORATION

15-5, 4-Chome, Ohmori-nishi, Ohta-ku, Tokyo, Japan

U.S. PIONEER ELECTRONICS CORPORATION

178 Commerce Road, Carlstadt New Jersey 07072 U.S.A.

PIONEER ELECTRONIC (EUROPE) N.V.

Noorderlaan 83, 2030 Antwerp, Belgium

COPYRIGHT © SEPT. 1971 PRINTED IN JAPAN